



TECHNICAL MANUAL

CDX

CDX:EXP

CDX:SL

CDN

BELT LINE SPECIFICATIONS | SPROCKET DIMENSIONS | FRAME DESIGN | BELT INSTALLATION & TENSIONING



TESTED | PROVEN | TRUSTED

2019



CARBON DRIVE™

Gates Carbon Drive products meet or exceed the standards set forth in the applicable requirements in ISO 4210-2:2014 and ISO 4210-8:2014. While individual Carbon Drive components sold by Gates meet or exceed these ISO requirements, it is the sole responsibility of the bicycle original equipment manufacturer (OEM) to configure the Gates Carbon Drive components in a way that meets or exceeds the ISO requirements for their particular bicycle model, especially regarding protective devices.

Note: All dimensions in millimeters unless otherwise noted.

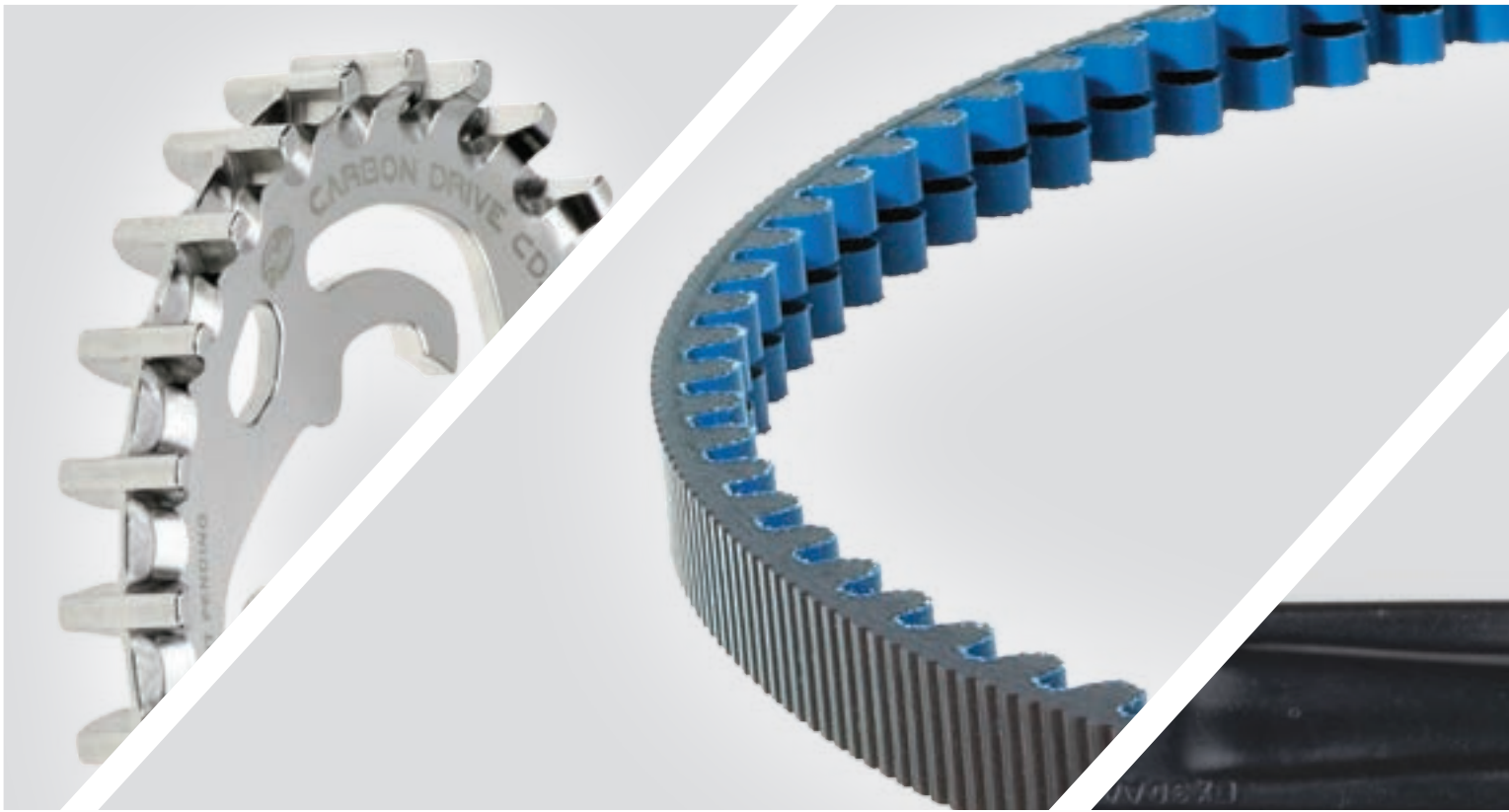

CONTENTS

6 Frame Design

Belt + Sprocket Calculator	6
Center Distance Adjustment	6
Frame Break	7
Dropout Designs: Horizontal + Vertical	8
Rear Triangle Stiffness	9
Crank/Sprocket Assembly Tolerances	9
Centerline Offset + Axis Alignment	10
Suspension Frame Considerations	11
Brakes	11

12 Belt Tensioning

Gates Krikit Tension Gauge	12
Professional Belt Tension Gauge	14
Eco Tension Tester	15
Gates Carbon Drive Mobile App	16
Sonic Tension Meter 508C	16

17 Cranksets

S550	18
S501	20
S300	22
S250	24
S150	26
S100	28
Thun ZUMBA Bottom Bracket Selection Guide	30

31 eBike Specific Products

Bosch GEN3	32
Bosch GEN2	33
Shimano STEPS E6100	34

35 Front Sprockets

4-Bolt 104 mm BCD	36
5-Bolt 130 mm BCD	36
Pinion	37



CARBON DRIVE™

38 Rear Sprockets

3-Lobe SureFit Shimano	39
9-Spline	40
9-Spline 6-Bolt	41
enviolo	42
Rohloff	43
Sturmey-Archer	44
Freewheel / Track (Thread On)	45

46 Gates Carbon Drive Belts

CDX CenterTrack Belts	47
CDN CenterTrack Belts	48

49 Tandem Products

CenterTrack Belt + Tandem Sprockets	49
-------------------------------------	----

50 Carbon Drive System Specifications

Belt Line Specifications

Mid-Mount Drive Systems

Bosch/Pinion	51
--------------	----

Internal Gear Hubs

enviolo	52
Shimano	53
Rohloff	54

Safety	55
--------	----

Handling the Belt	56
-------------------	----

Care for your Carbon Drive System	57
-----------------------------------	----

Proper Alignment	57
------------------	----

Rear Wheel Removal + Installation	58
-----------------------------------	----

Replace When Worn	59
-------------------	----

Gates Sprocket Tools	60
----------------------	----

Troubleshooting	61
-----------------	----

Glossary of Terms	64
-------------------	----

65 Warranty	65
-------------	----



Gates® Carbon Drive™ Bicycle Calculator
[Get your Design Guide here](#)



CARBON DRIVE™

Front Chainring (Teeth)

Rear Cog (Teeth)

Gear Ratio

Chainstay (mm)

Advanced Options

Tire Size

Crank (mm)

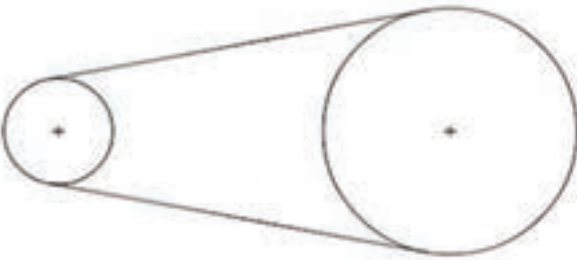

Front Sprocket mounts:
3 bolt 130mm BCD

Rear Sprocket mounts:
9 spline hub

Rank	Gear Ratio	Front Sprocket (Teeth)	Rear Sprocket (Teeth)	Belt Length (Teeth)	Chainstay Length (mm)
1	2.333	70	30	120	378.50
2	2.333	70	30	118	367.30
3	2.333	70	30	115	350.48
4	2.333	70	30	113	339.25

BELT + SPROCKET CALCULATOR

Sprocket selection is impacted by the target gear ratio, frame chainstay length, and available belt lengths. To simplify the selection process, use our drive calculator by downloading from www.GatesCarbonDrive.com/Tech/Overview

CENTER DISTANCE ADJUSTMENT

To allow for belt installation and tensioning, adjustment in the chainstay length or “Center Distance” is required. To install a belt, there must be enough room so the belt can slip over the sprockets, achieved by decreasing the Center Distance between sprockets. See page 58 for a visual example of Center Distance slackening. It is important to note that the belt must be installed loose, not rolled or pried onto the sprockets while under tension.

Once the belt is installed onto the sprockets, there must be a way to take up the slack in the drive. If only one ratio is desired for the application, a minimum range of movement of 12 mm is needed – 10 mm shorter than nominal for installation room, and 2 mm longer than nominal for tensioning and tolerance take-up. More Center Distance range may be desired to enable the bike to use different sprockets enabling multiple gear ratio combinations.

Center distance adjustments are typically made through rear axle movement with a sliding dropout, horizontal dropout, or bottom bracket axle movement with an eccentric bottom bracket. When using an eccentric bottom bracket, pay close attention to the sprocket selection, chainstay length, and Center Distance due to the limited range of adjustment typical eccentric bb shells provide.

FRAME DESIGN

INCORPORATING A GATES CARBON DRIVE BELT SYSTEM REQUIRES AN OPENING IN THE REAR TRIANGLE.

FRAME BREAK

To incorporate a belt drive, a bicycle frame requires an opening in the rear triangle. Without a master link, a belt requires an opening in the rear triangle to be installed. The opening can be at the dropout or can be in one of the stays. Frame manufacturers have found various ways to accommodate the opening.



THERE ARE MANY DIFFERENT STYLES OF DROPOUTS AVAILABLE BUT MOST GENERALLY FALL INTO TWO CATEGORIES - HORIZONTAL AND VERTICAL.

DROPOUT DESIGN

VERTICAL DROPOUTS

The benefit to a vertical dropout is that once tension and alignment of the belt have been set (assuming the mounting hardware has been properly tightened), the rear wheel can be released, and reinstalled without having to start over with the alignment and tensioning process. Furthermore, quick release type skewers can be used, because the clamping force of the skewer is not holding the belt tension. Vertical dropouts do not possess, by themselves, a center distance change, or tension adjustment capability. This means a secondary tension mechanism is required (eccentric bottom bracket, eccentric hub, or dropout slider).



HORIZONTAL DROPOUTS

Horizontal dropout designs are not ideal for belt drives. Horizontal dropouts almost always have some sort of center distance adjustment, allowing the use of various belt lengths and sprocket combinations. A key factor to consider is the need to realign and tension the belt every time you take the belt off or need to remove the rear wheel. Component selection is also important when using horizontal dropouts and may be more limited. For example, a standard 5 mm quick release does not produce the necessary clamping force to keep the rear wheel from moving under heavy loading, therefore features such as positive tensioning stops must be built into the dropouts or secondary axle tension devices may be required.



FRAME STIFFNESS

WHY IS IT IMPORTANT?

The stiffness of a frame's rear triangle plays a major role in the performance of the belt drive system.

If the rear triangle of a frame is too flexible, it is possible that frame deflection can result in tooth jumping, accelerated wear, drivetrain noise, or in extreme cases, belt derailment. Excessively high rear triangle stiffness can result in an uncomfortable ride.

HOW IS IT MEASURED?

Gates engineers have developed a method for measuring rear triangle stiffness, and this evaluation service is offered by Gates to all frame designers as a product development tool. Frame testing requires submission of a complete frameset to one of our three engineering development centers located in Germany, Taiwan, and USA.

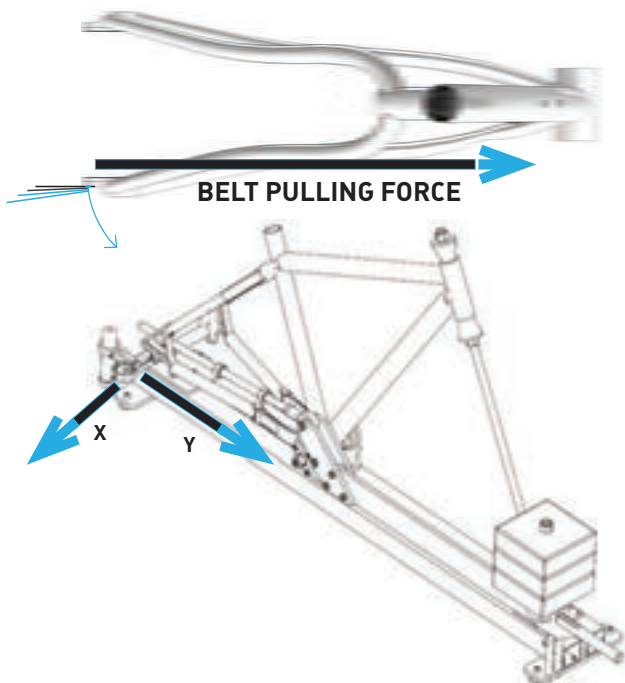

STIFFNESS REQUIREMENTS:

Bicycle Type	X Quotient (minimum)	Y Quotient (minimum)
MTB, Trekking, Sportive, Cargo bicycles and mid-motor eBikes	5.0 kg/mm	26.5 kg/mm
City, Urban, Commuter bicycles, including front and rear hub motor eBikes	4.0 kg/mm	22.0 kg/mm

Note: Bicycles equipped with the Rohloff Speedhub need to pass the MTB/Trekking/Sportive standard.

ADDITIONAL INFORMATION GatesCarbonDrive.com/FrameStiffness

CRANK/SPROCKET ASSEMBLY TOLERANCES:

To ensure optimal performance of belt drives, Gates requires the following runout tolerances for crank/sprocket assemblies measured with the intended bottom bracket. Excessive runout can result in large tension variation, improper shifting on geared hubs, and even premature belt failure.

Total radial runout allowed is less than or equal to 0.25mm measured at diameter over teeth. Total axial runout allowed is less than or equal to 1.0mm measured at CenterTrack flange surface.

Radial Runout/Concentricity
Diameter Over Teeth
 $\leq 0.25 \text{ mm}$

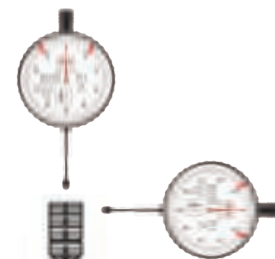

Axial Runout/Flatness
CenterTrack Flange Surface
 $\leq 1.0 \text{ mm}$



FRAME DESIGN

THERE ARE 3 PRIMARY TYPES OF REAR TRIANGLE ALIGNMENT WHICH DIRECTLY IMPACT THE PERFORMANCE OF THE BELT DRIVE SYSTEM.

CENTERLINE OFFSET

The distance between the center plane of the frame and the inside face of the dropout.

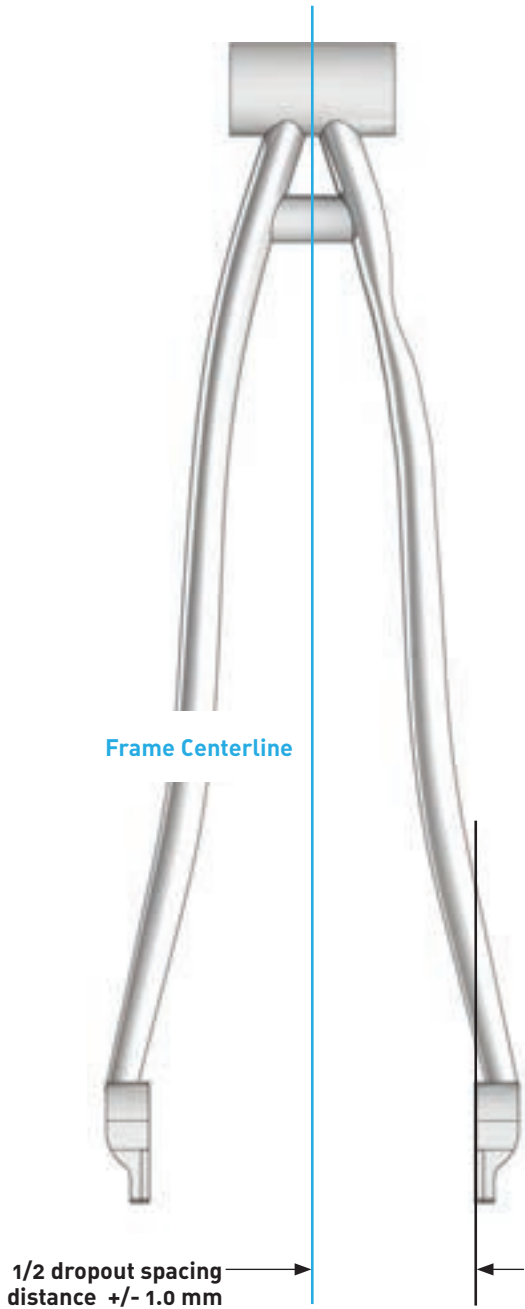

AXIS ALIGNMENT

VERTICAL PLANE Refers to the parallel relationship between the axis of the bottom bracket and the axis of the rear hub in the vertical plane.

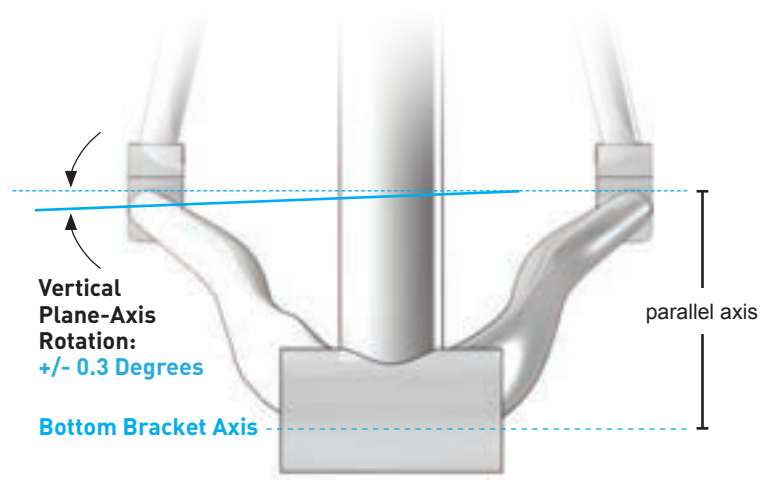

HORIZONTAL PLANE Refers to the parallel relationship between the axis of the bottom bracket and the axis of the rear hub in the horizontal plane.

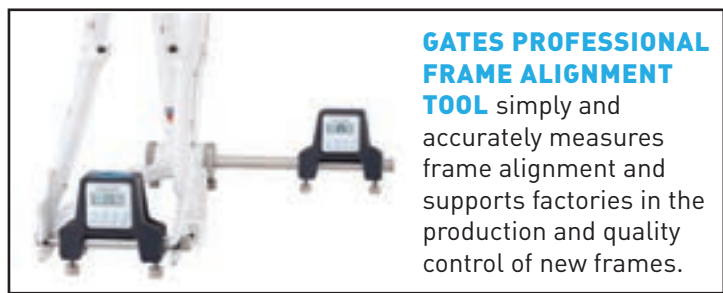
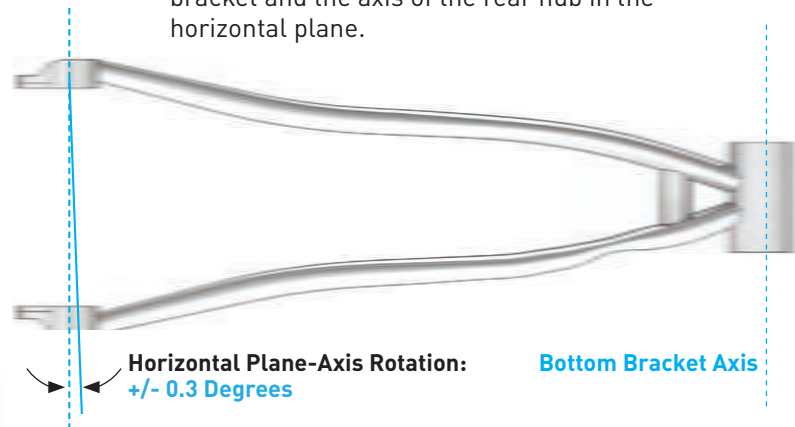

GATES PROFESSIONAL FRAME ALIGNMENT TOOL simply and accurately measures frame alignment and supports factories in the production and quality control of new frames.

FRAME DESIGN

SUSPENSION FRAME CONSIDERATIONS

In the earliest possible stages of designing a Carbon Drive compatible rear suspension frame, there are critical engineering factors which must be taken into consideration. In general, full suspension frame designs result in some form of chain growth. Chain growth being defined as a change in the resting distance between the axis of the bottom bracket axle and the axis of the rear hub axle. Because the belt does not have the ability to stretch and the tension in the belt must remain constant, even the smallest amount of chain growth during suspension travel would be detrimental to the system integrity. Devices which compensate for drivetrain slack - such as spring loaded idlers or chain guides - are not allowed unless specifically reviewed and approved by Gates.

If a full suspension frame design which utilizes the Carbon Drive system is desired, please contact the Carbon Drive Team (CarbonDrive@Gates.com) for engineering and development assistance.

BRAKES

Gates recommends that hand brakes are used as the primary braking system. Gates does not recommend the use of brake systems that incorporate the use of the belt drive as the only brake system, such as coaster brakes and fixed gears. If belt drive brake systems are installed, Gates requires a hand brake as a secondary braking system.

Always use Gates Carbon Drive belts with authentic Gates Carbon Drive sprockets

Gates engineers have invested significant time designing, developing and testing the patented belts and sprockets to ensure optimal performance. Gates will not warranty the belts or sprockets if used with a substitute part from another manufacturer. Always use Gates Carbon Drive belts with authentic Gates Carbon Drive sprockets.



BELT TENSIONING

PROPER BELT TENSION IS ESSENTIAL FOR OPTIMUM OPERATION OF THE GATES CARBON DRIVE SYSTEM.

Lack of belt tension can lead to tooth jump or “skipping”, when the teeth of the belt slide over the teeth of the rear sprocket. Too much tension can damage bearings, can cause the system to drag, and can increase the wear of your drive system.

Tensioning procedures vary depending on the bike. Common types of tensioning systems include sliding or pivoting dropouts and eccentric bottom brackets. **Note – correct alignment of the belt has to be maintained as you adjust tension.**

There are 3 common methods for measuring tension on your Carbon Drive system: the Gates Kriket Tension Gauge, the Eco Tension Tester, and the Gates Carbon Drive Mobile App for iPhone® and Android®. For each of these, the tension may vary a little along the belt, so you should repeat this procedure several times. Rotate the cranks a quarter turn after each measurement and measure again.

The tools only measure tension, they do not specify a needed tension. Refer to the chart below for the correct tension range recommendation for your Gates Carbon Drive setup.

WARNING: Do not touch the Kriket gauge with a second finger. This process is a one finger operation.



TENSION RECOMMENDATIONS

	SMOOTH & STEADY PEDALING STYLE	PUNCHY & ROUGH PEDALING STYLE
Mountain* and Single Speed Urban	45-60 Hz (35-45 lbs)	60-75 Hz (45-53 lbs)
Internal Gear Hub	35-50 Hz (28-40 lbs)	
Tandem	60-65 Hz (45-48 lbs)	

These tension recommendations are a good starting point, which may need to be adjusted higher or lower based on the rider size, gear ratio, and power placed on the pedals.

* The CDN System is not approved for use on mountain bikes, mid-drive eBikes or gear boxes, fixed gear bikes, or high mileage trekking/touring bikes.

GATES KRIKIT TENSION GAUGE

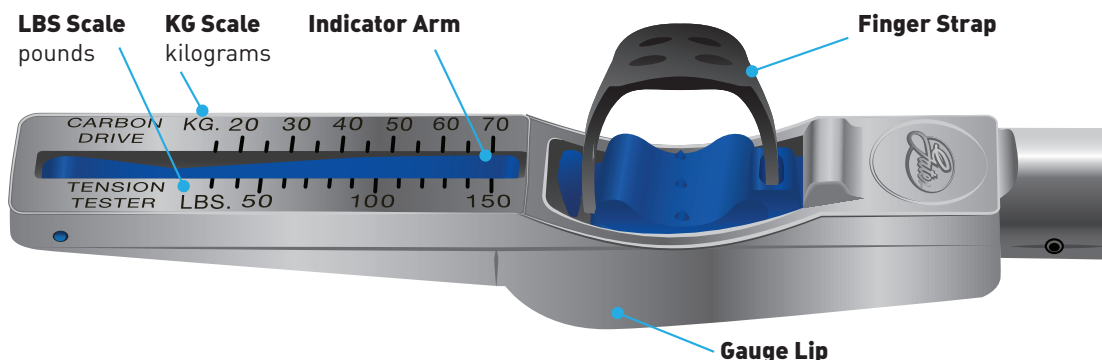

BELT TENSIONING

CHECKING BELT TENSION: GATES KRIKIT TENSION GAUGE

1

Verify Indicator Arm is positioned completely down. Place index finger in the rubber Finger Strap, on top of the Click Pad, as shown.

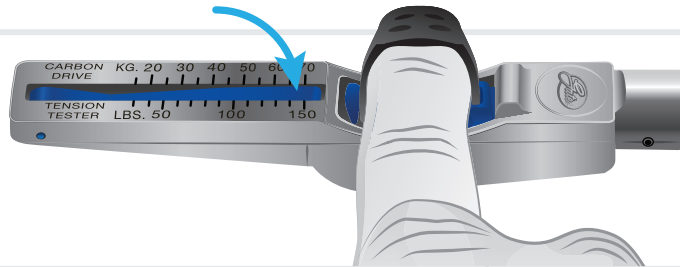

2

Place Kriket Gauge on top of the belt and position the gauge in the middle of the total belt span, making sure the Gauge Lip sits flush against the belt.

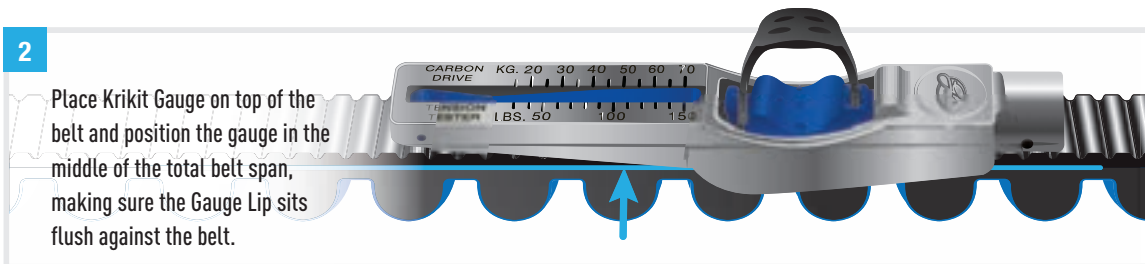

3

Press down on tester click pad until it clicks. It is critical to use only one finger on the gauge.

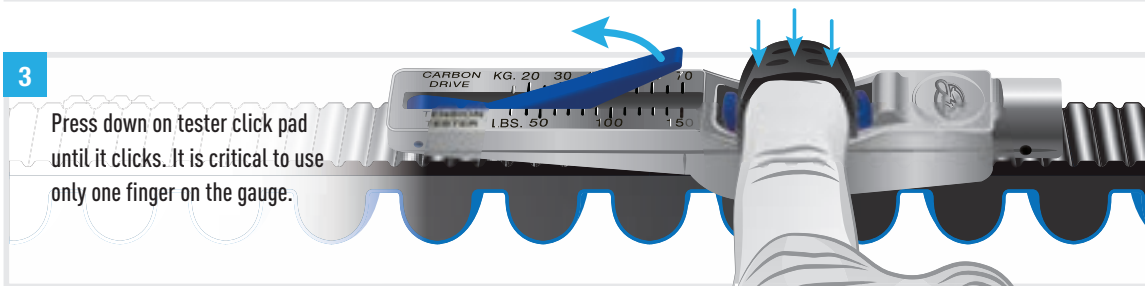

4

Measurement point is the intersection of lines **A** and **B**. The gauge tension reading shown is: **20 KG (40 LB)**

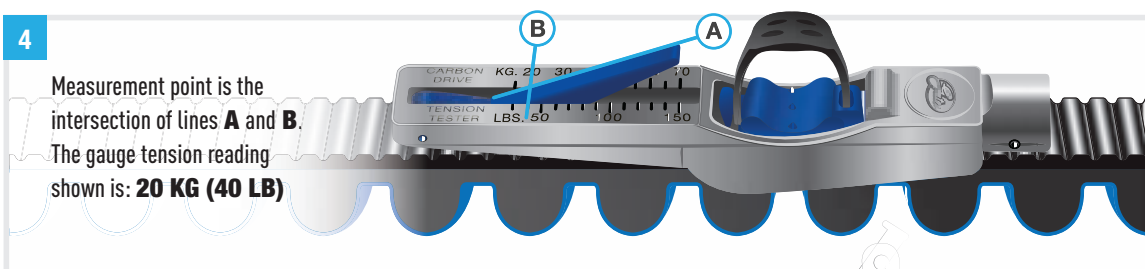

5

Rotate crank one-quarter turn and repeat previous steps 1 to 4. Repeat rotation and measurement no fewer than 3 times.

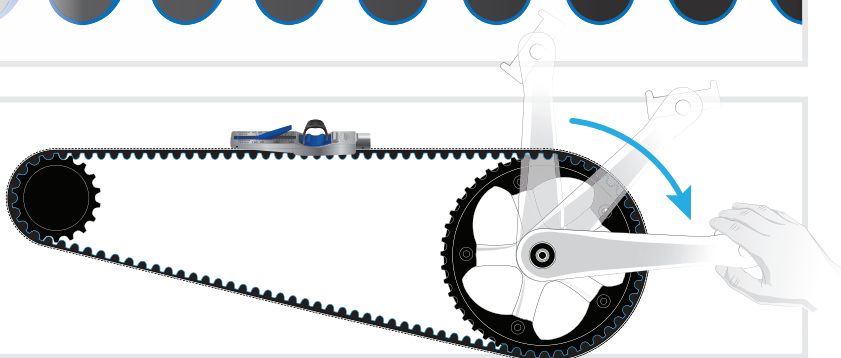

BELT TENSIONING

CHECKING BELT TENSION: PROFESSIONAL BELT TENSION GAUGE

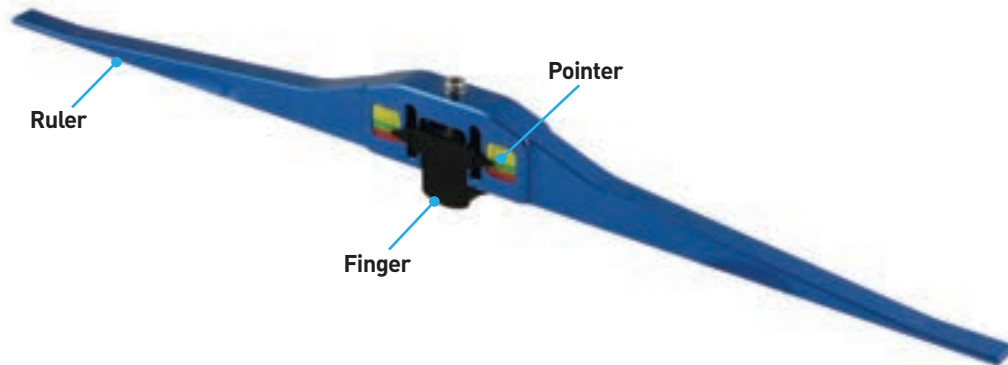

Reset the pointer to zero.

Note: Pointer must be reset before each measurement.



Contacting both sprockets, measure the belt tension across the span.



Too much belt tension



Optimal belt tension



Too little belt tension

BELT TENSIONING

CHECKING BELT TENSION: ECO TENSION TESTER

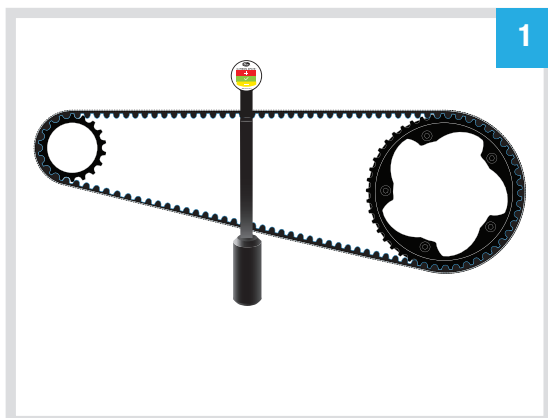
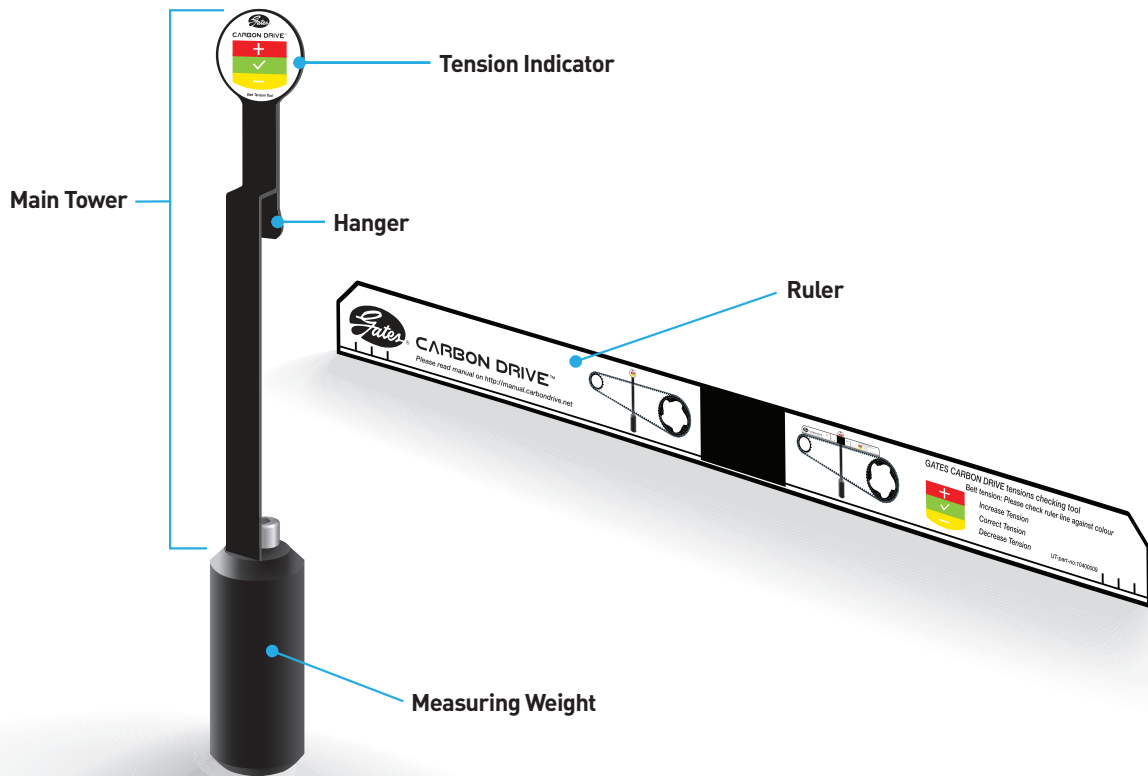

Hang the main tower on the belt.

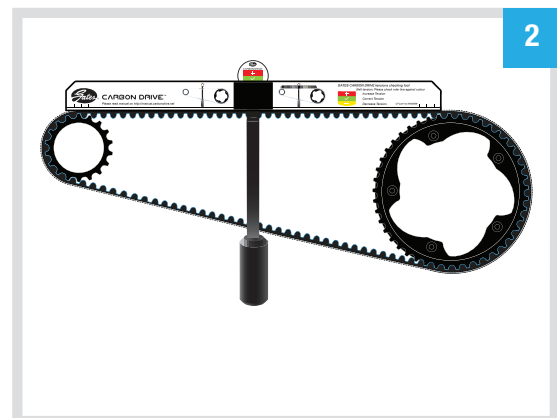

Put the ruler on the two sprockets. Check the tension:

+	Red	Increase the tension
✓	Green	Tension is good
-	Yellow	Decrease the tension

CHECKING BELT TENSION: GATES CARBON DRIVE MOBILE APP [FOR IPHONE & ANDROID]

Gates Carbon Drive Mobile App measures belt tension from the natural frequency (Hz) of the belt span. Using the microphone, the App converts the sound into the primary frequency of the belt.

From the App, click the Tension icon and then click Measure. Hold the device microphone (be sure microphone is 'on') facing the belt. Pluck the belt so that it vibrates similar to a guitar string. Rotate the crank $\frac{1}{4}$ turn and repeat the frequency measurement. Compare your belt's frequency to the chart on pg 12 to review any necessary tension adjustments. The Gates Carbon Drive Mobile App works best in a quiet environment.

- Find key parameters of your drive such as speed ratio and center distance
- Change belt length or sprocket sizes to better suit your riding needs
- Compare two belt drive bikes to each other
- Check out what sprocket sizes, mounting options, and belt lengths are available in our catalog
- Check tension with our frequency measuring tool (iPod Touch needs an external microphone)



CHECKING BELT TENSION: SONIC TENSION METER 508C

The Gates Sonic Tension Meter measures belt tension by analyzing the harmonic characteristics of a vibrating belt. Simply pluck the belt like a guitar string and the meter will take a reading and provide a highly accurate tension measurement.

COMPACT SIZE About the size of a cellular telephone, the Sonic Tension Meter can easily be operated by one person for fast, accurate readings

Note: Perfect for factory installation.



CRANKSETS

PRE-ASSEMBLED, SAVING TIME AND EXPENSE

S550



18

S501



20

S300



22

S250



24

S150



26

S100



28

CRANKSETS

SIMPLIFIES THE SETUP OF CARBON DRIVE SYSTEM WITH INTERNAL GEAR HUBS.

S550 CDX:EXP



PRE-ASSEMBLED TO PROVIDE HIGHEST VOLUME SHIMANO, ENVIOLLO, AND ROHLOFF BELTLINES

SAVES VALUABLE TIME IN PRODUCTION

46T, 50T, AND 55T DIRECT MOUNT 7075-T6 CDX:EXP SPROCKETS

FORGED 6061 CRANK ARMS WITH 24MM CHROMOLY SPINDLE

INCLUDES 68/73 MM BOTTOM BRACKET

AVAILABLE WITH OR WITHOUT ISO-COMPLAINT GUARD

170 AND 175 MM CRANK ARM LENGTH

AVAILABLE IN MATTE BLACK



Shown with ISO-compatible guard.

CRANKSETS

GATES S550

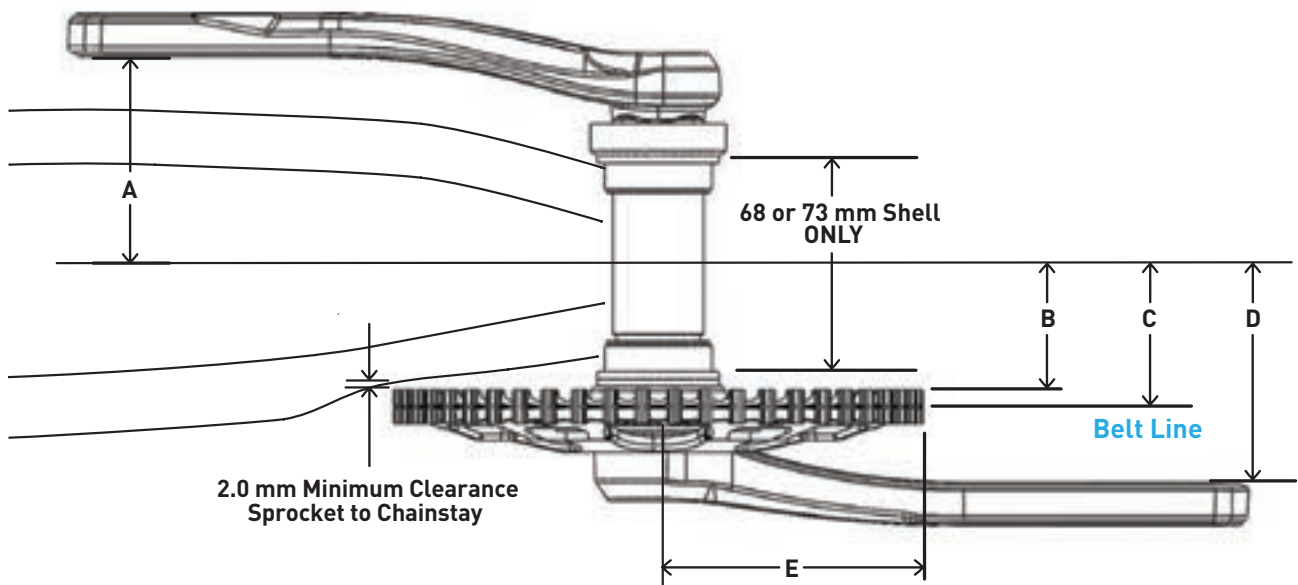

S550 CRANKSET FOR USE WITH CDX:EXP SPROCKETS

Teeth	Part Number	Arm Length	DIMENSION				
			A	B	C- Belt Line	D	E
46	FC550 170BM 46CDX -0/45.5 BG	170	69.0	40.0	45.5	70.4	79.6
46	FC550 175BM 46CDX -0/45.5 BG	175					86.6
50	FC550 170BM 50CDX -0/45.5 BG	170					95.4
50	FC550 175BM 50CDX -0/45.5 BG	175					79.6
55	FC550 170BM 55CDX -0/45.5 BG	170					86.6
55	FC550 175BM 55CDX -0/45.5 BG	175					95.4
46	FC550 170BM 46CDX -0/54.7 BG	170		49.2	54.7	70.4	79.6
46	FC550 175BM 46CDX -0/54.7 BG	175					86.6
50	FC550 170BM 50CDX -0/54.7 BG	170					95.4
50	FC550 175BM 50CDX -0/54.7 BG	175					79.6
55	FC550 170BM 55CDX -0/54.7 BG	170					86.6
55	FC550 175BM 55CDX -0/54.7 BG	175					95.4

For beltlines not listed, please contact your Gates Carbon Drive technical representative.

"BG" at end of Part Number specifies inclusion of an ISO compliant Black Guard. Alternatively "NG" would specify No Guard.

CRANKSETS

SIMPLIFIES THE SETUP OF CARBON DRIVE SYSTEM WITH INTERNAL GEAR HUBS.

S501
CDX



*PROVIDES THE SPECIFIC BELT LINE REQUIRED
WHEN PAIRED WITH SHIMANO INTERNAL GEAR HUBS*

SAVES VALUABLE TIME IN PRODUCTION

*CONCENTRIC ASSEMBLY MINIMIZES VARIATION
OF BELT TENSION*

*ALLOWS FOR MECHANICAL AND Di2 BELT LINE
OPTIONS*

170 CRANK LENGTH

RECOMMENDED BOTTOM BRACKET: SMBB4600

AVAILABLE IN POLISHED BLACK

CRANKSETS

GATES S501

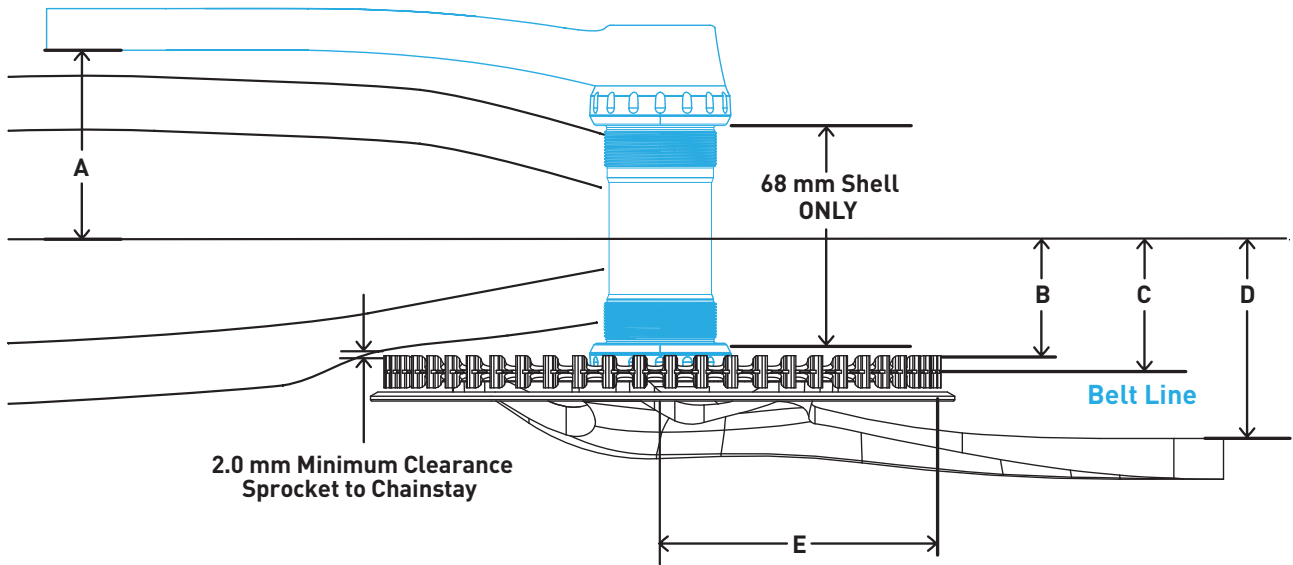

S501 CRANKSET FOR USE WITH CDX SPROCKETS

Teeth	Part Number	Arm Length	DIMENSION				
			A	B	C- Belt Line	D	E
MECHANICAL VERSION							
50	S501 170 50T	170	63.3	38.2 +/- 0.5	43.7 +/- 0.5	63.3	86.6
55	S501 170 55T	170					95.4
Di2 VERSION							
50	S501 170 50T Di2	170	63.3	34.3 +/- 0.5	39.8 +/- 0.5	63.3	86.6
55	S501 170 55T Di2	170					95.4

CRANKSETS

SIMPLIFIES THE SETUP OF CARBON DRIVE SYSTEM WITH INTERNAL GEAR HUBS.

S300 CDX



*PROVIDES THE SPECIFIC BELT LINE REQUIRED
WHEN PAIRED WITH SHIMANO INTERNAL GEAR HUBS.*

SAVES VALUABLE TIME IN PRODUCTION

*CONCENTRIC ASSEMBLY MINIMIZES VARIATION
OF BELT TENSION*

*ALLOWS FOR MECHANICAL AND Di2 BELT LINE
OPTIONS*

68 MM GXP GUTTER BOTTOM BRACKET INCLUDED

170 AND 175 MM CRANK LENGTH OPTIONS

COMPATIBLE GEARED HUBS:

*SHIMANO: Di2, ALFINE 11, ALFINE 8, NEXUS 5,
NEXUS 3 (MODELS SG-3D55 & SG-3C41),*

SRAM: i-Motion 3

AVAILABLE IN POLISHED BLACK OR MATTE SILVER

*AVAILABLE WITH ISO COMPATIBLE
COMPOSITE GUARD*



CRANKSETS

GATES S300

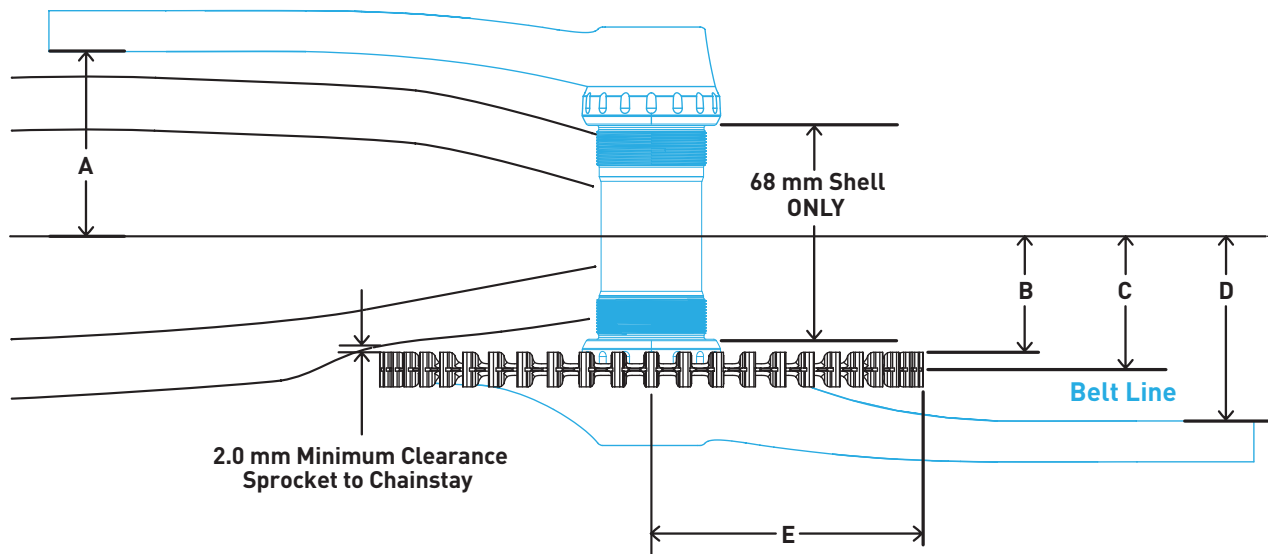

S300 CRANKSET FOR USE WITH CDX SPROCKETS

Teeth	Part Number	Arm Length	DIMENSION				
			A	B	C- Belt Line	D	E
MECHANICAL VERSION							
46	S300 GXP 175 46T	175	60 +2/-1	38.2 +/-0.5	43.7 +/-0.5	60 +2/-1	79.6
46	S300 GXP 170 46T	170					79.6
50	S300 GXP 175 50T	175					86.6
50	S300 GXP 170 50T	170					86.6
55	S300 GXP 175 55T	175					95.4
55	S300 GXP 170 55T	170					95.4
60	S300 GXP 175 60T	175					104
60	S300 GXP 170 60T	170					104
Di2 VERSION							
50	S300 GXP 175 50T Di2	175	60 +2/-1	34.3 +/-0.5	39.8 +/-0.5	60 +2/-1	86.6
50	S300 GXP 170 50T Di2	170					86.6
55	S300 GXP 175 55T Di2	175					95.4
55	S300 GXP 170 55T Di2	170					95.4
60	S300 GXP 175 60T Di2	175					104
60	S300 GXP 170 60T Di2	170					104

CRANKSETS

SIMPLIFIES THE SETUP OF CARBON DRIVE SYSTEM WITH INTERNAL GEAR HUBS.

S250

CDX / CDN



PROVIDES THE SPECIFIC BELT LINE REQUIRED WHEN PAIRED WITH RECOMMENDED BOTTOM BRACKET.

SAVES VALUABLE TIME IN PRODUCTION

CONCENTRIC ASSEMBLY MINIMIZES VARIATION OF BELT TENSION

*RECOMMENDED BOTTOM BRACKET:
ZUMBA FROM THUN*

170 AND 175 MM CRANK LENGTH OPTIONS

AVAILABLE IN MATTE BLACK OR MATTE SILVER WITH POLISHED RAISED SURFACE

PREASSEMBLED WITH MATCHING ALUMINUM ISO COMPATIBLE GUARD

CRANKSETS

GATES S250

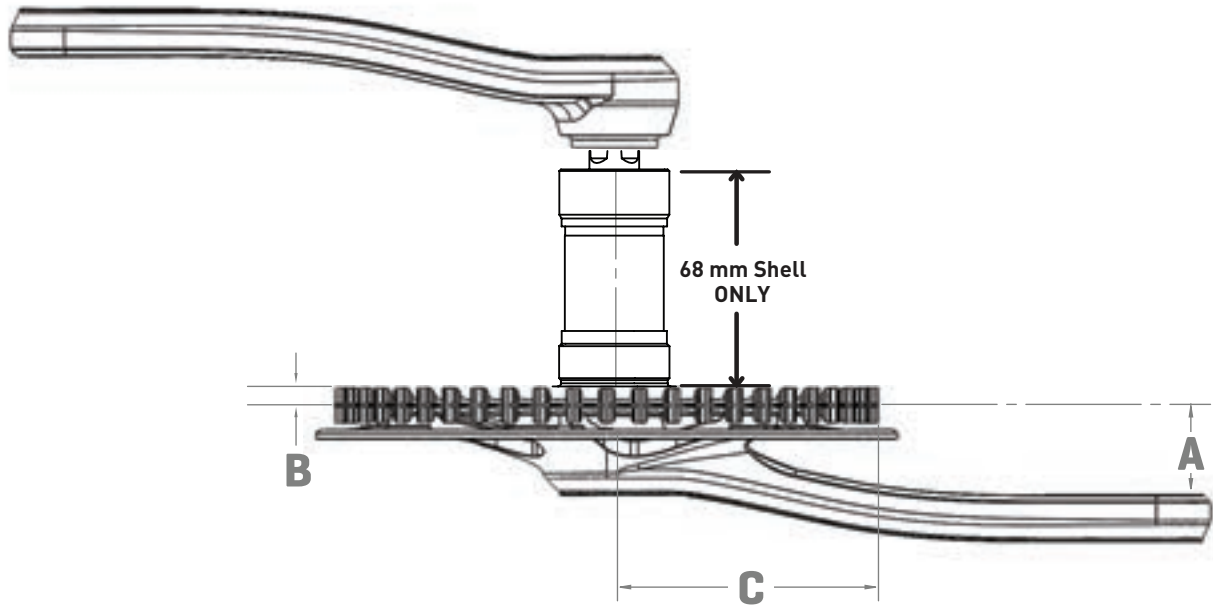

GATES S250 CRANKSET FOR USE WITH CDX OR CDN SPROCKETS

Teeth	Part Number	Arm Length	DIMENSION (MM)			
			A		B	C
			CDX	CDN		
46	FC S250 JIS 170 46T BG	170	28.8	28.3	5.5	79.6
46	FC S250 JIS 175 46T BG	175				79.6
50	FC S250 JIS 170 50T BG	170				86.6
50	FC S250 JIS 175 50T BG	175				86.6
55	FC S250 JIS 170 55T BG	170				95.4
55	FC S250 JIS 175 55T BG	175				95.4

For beltline and bottom bracket selection, refer to pg 30.

"BG" or "SG" at end of Part Number specifies inclusion of an ISO compliant Black Guard or Silver Guard.

CRANKSETS

SIMPLIFIES THE SETUP OF CARBON DRIVE SYSTEM WITH INTERNAL GEAR HUBS.

S150

CDX / CDN



PROVIDES THE SPECIFIC BELT LINE REQUIRED WHEN PAIRED WITH RECOMMENDED BOTTOM BRACKET.

SAVES VALUABLE TIME IN PRODUCTION

CONCENTRIC ASSEMBLY MINIMIZES VARIATION OF BELT TENSION

*RECOMMENDED BOTTOM BRACKET:
ZUMBA FROM THUN*

170 AND 175 MM CRANK LENGTH OPTIONS

*AVAILABLE IN MATTE BLACK
OR MATTE SILVER*

*AVAILABLE WITH ISO COMPATIBLE
COMPOSITE GUARD*



Shown with ISO-compatible guard.

CRANKSETS

GATES S150

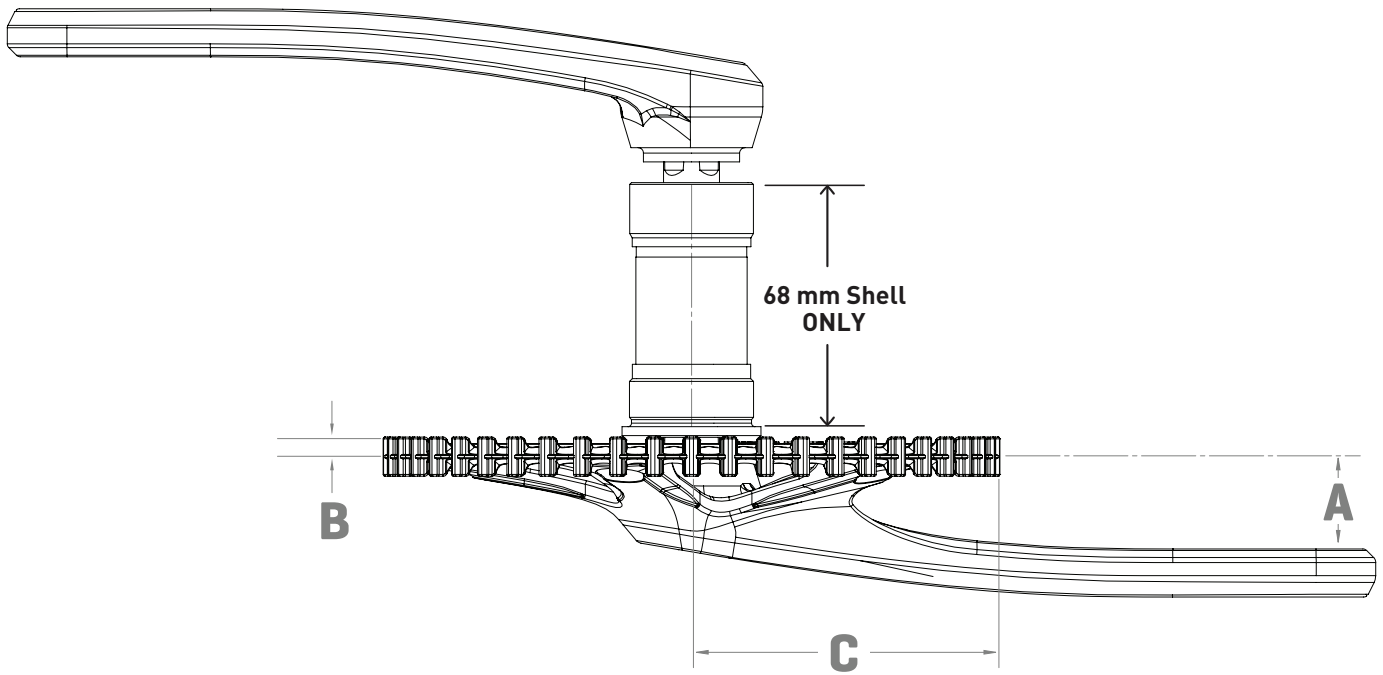

GATES S150 CRANKSET FOR USE WITH CDX OR CDN SPROCKETS

Teeth	Part Number	Arm Length	DIMENSION (MM)			
			A		B	C
			CDX	CDN		
46	FC S150 JIS 170 46T	170	30.0	29.5	5.5	79.6
46	FC S150 JIS 175 46T	175				79.6
50	FC S150 JIS 170 50T	170				86.6
50	FC S150 JIS 175 50T	175				86.6
55	FC S150 JIS 170 55T	170				95.4
55	FC S150 JIS 175 55T	175				95.4

For beltline and bottom bracket selection, refer to pg 30.

CRANKSETS

SIMPLIFIES THE SETUP OF CARBON DRIVE SYSTEM WITH INTERNAL GEAR HUBS.

S100

CDX / CDN



PROVIDES THE SPECIFIC BELT LINE REQUIRED WHEN PAIRED WITH RECOMMENDED BOTTOM BRACKET.

SAVES VALUABLE TIME IN PRODUCTION

CONCENTRICITY MINIMIZES VARIATION OF BELT TENSION

*RECOMMENDED BOTTOM BRACKET:
ZUMBA FROM THUN OR RPM FROM FSA*

170 AND 175 MM CRANK LENGTH OPTIONS

AVAILABLE IN POLISHED BLACK

CRANKSETS

GATES S100

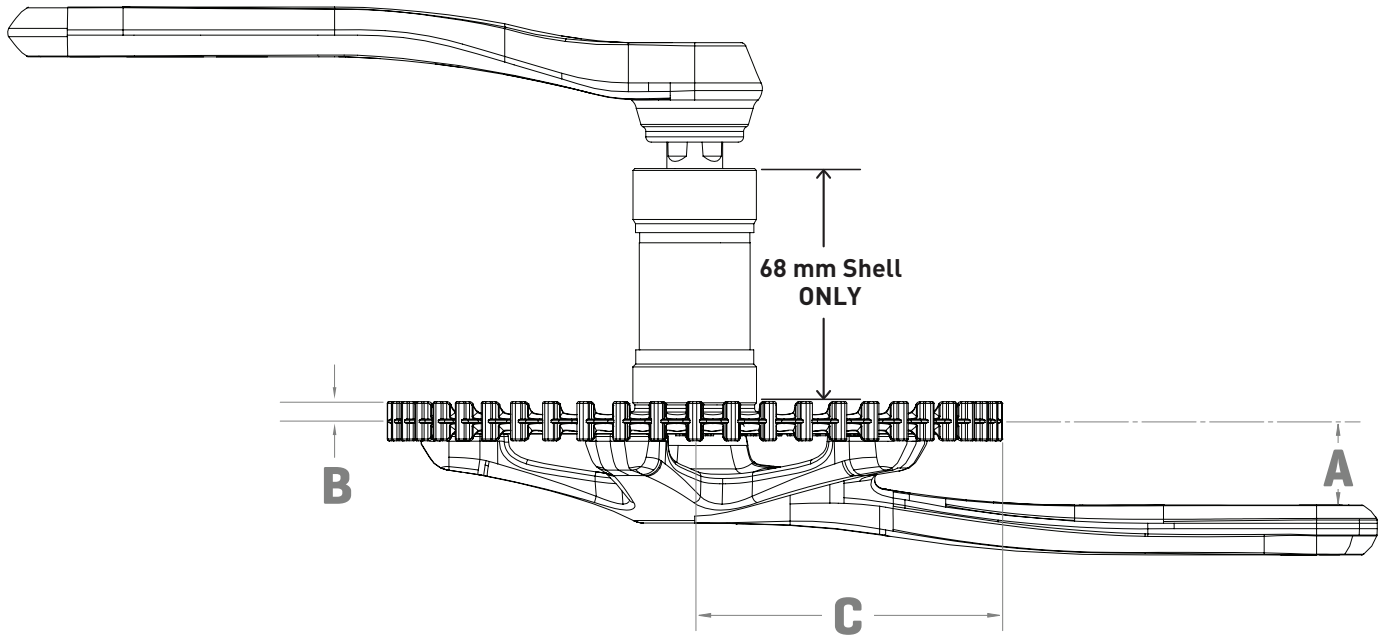

GATES S100 CRANKSET FOR USE WITH CDX OR CDN SPROCKETS

Teeth	Part Number	Arm Length	DIMENSION (MM)			
			A		B	C
			CDX	CDN		
46	FC S100 JIS 170 46T	170	20.5	20	5.5	79.6
46	FC S100 JIS 175 46T	175				79.6
50	FC S100 JIS 170 50T	170				86.6
50	FC S100 JIS 175 50T	175				86.6
55	FC S100 JIS 170 55T	170				95.4
55	FC S100 JIS 175 55T	175				95.4

For beltline and bottom bracket selection, refer to pg 30.

CRANK ASSEMBLIES BOTTOM BRACKET SELECTION GUIDE

S100 & S150

	Hub	Brake Type	Model No.	O.L.D.	Beltline													
enviolo	ALL	Disc, Rim, Roller	ALL	135	45.5												●	
Rohloff	500/14	Disc, Rim	500/14	135	54.7												●	
Shimano	Nexus 3	Coaster	SG-3D55	135	43.8												●	
	Nexus 3	Coaster	SG-3C41 (120 O.L.D.)	120	43.0												●	
	Nexus 3	Coaster	SG-3C41 (127 O.L.D.)	127	41.5												●	
	Nexus 7	Coaster	SG-C3000-7C	127	43.3													●
	Nexus 7	Roller	SG-C3000-7R	130	42.1													●
	Nexus 8	Coaster	SG-C6001-8C	132.3	44.8													●
	Nexus 8	Roller, Rim	SG-C6011-8R, SG-C6001-8R, SG-C6011-8V, SG-C6001-8V	132	44.6													●
	Nexus 8	Disc	SG-C6001-8D, SG-C6001-8CD	135	43.7													●
	Alfine 8	Disc	SG-S7001-8	135	43.7													●
	Alfine 11	Disc	SG-S700	135	43.7													●
	Nexus 8 Di2	Disc, Roller, Coaster	SG-C6061-8R, SG-C6061-8C, SG-C6061-8D, SG-C6061-8CD	135	39.8													●
	Alfine 8 Di2	Disc	SG-S7051-8	135	39.8													●
	Alfine 11 Di2	Disc	SG-S705	135	39.8													●
Sturmeier-Archer	S-RF3	Rim	IHS3F.QBSS.AA3, IHS3F.QCSS.AA3	117	42.5												●	
	RX-RF5	Rim	IHC5F.XBSS.AA0, IHC5F.XCSS.AA0	135	43.7												●	
						Type / Model	Zumba GBL 400	Zumba GBL 420	Zumba GBL 430	Zumba GBL 440	Zumba GBL 450	Zumba GBL 460	Zumba GBL 550					

thun ZUMBA

eBike™

EBIKE SPECIFIC PRODUCTS

BOSCH



32, 33

SHIMANO



34



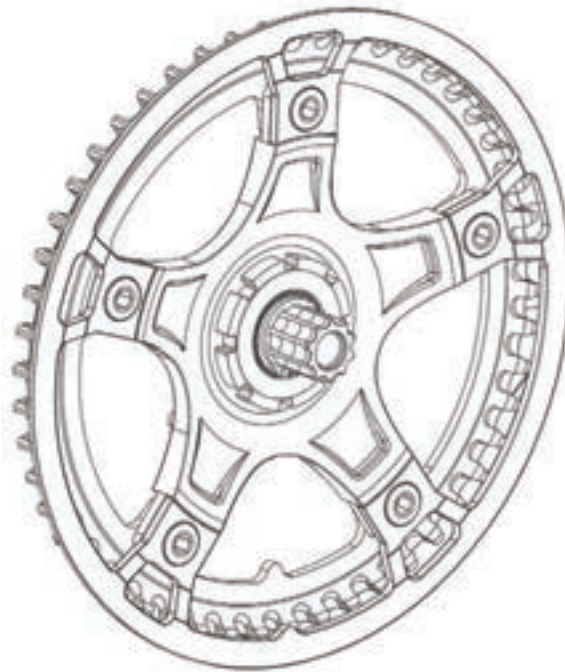

GEN3 ASSEMBLY SELECTION CHART

REAR HUB BRAND	COMPATIBLE HUBS	NOMINAL BELTLINE	FRONT SPROCKET TEETH	CENTERED NODE ASSEMBLY PART NUMBER	6MM OFFSET NODE ASSEMBLY PART NUMBER	REAR SPROCKET TYPE
Shimano	Alfine 8/11, Nexus 8 Disc	45.5MM	46	N/A	S5B3BM 46CDX -6/45.5 BG	XMN-U
			50	S5B3BM 50CDX -0/45.5 BG*	S5B3BM 50CDX -6/45.5 BG	
			55	S5B3BM 55CDX -0/45.5 BG*	S5B3BM 55CDX -6/45.5 BG	
			60	S5B3BM 60CDX -0/45.5 BG*	S5B3BM 60CDX -6/45.5 BG	
enviolo	enviolo CT, TR, SP, CA, CO (135/142mm OLD)	45.5MM	46	N/A	S5B3BM 46CDX -6/45.5 BG	VMN
			50	S5B3BM 50CDX -0/45.5 BG*	S5B3BM 50CDX -6/45.5 BG	
			55	S5B3BM 55CDX -0/45.5 BG*	S5B3BM 55CDX -6/45.5 BG	
			60	S5B3BM 60CDX -0/45.5 BG*	S5B3BM 60CDX -6/45.5 BG	
Rohloff	SpeedHUB 500/14 (135/142mm OLD)	54.7MM	46	S5B3BM 46CDX -0/54.7 BG	N/A	RMN-E/ RSMN
			50	S5B3BM 50CDX -0/54.7 BG		
			55	S5B3BM 55CDX -0/54.7 BG		
			60	S5B3BM 60CDX -0/54.7 BG		

For hubs or beltlines not listed, please contact your Gates Carbon Drive technical representative.

"BG" at end of Part Number specifies inclusion of an ISO compliant Black Guard. Alternatively "NG" would specify No Guard.

* Compatibility with Active Line Plus only. Interference may occur with Active Line stock cosmetic cover.

Custom covers may eliminate this interference.

Reference Gates Carbon Drive eBike Integration Manual for detailed information.

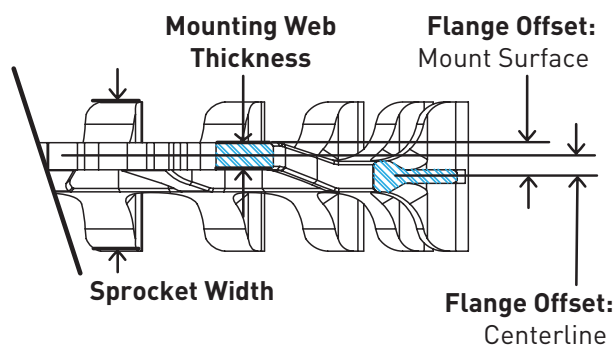
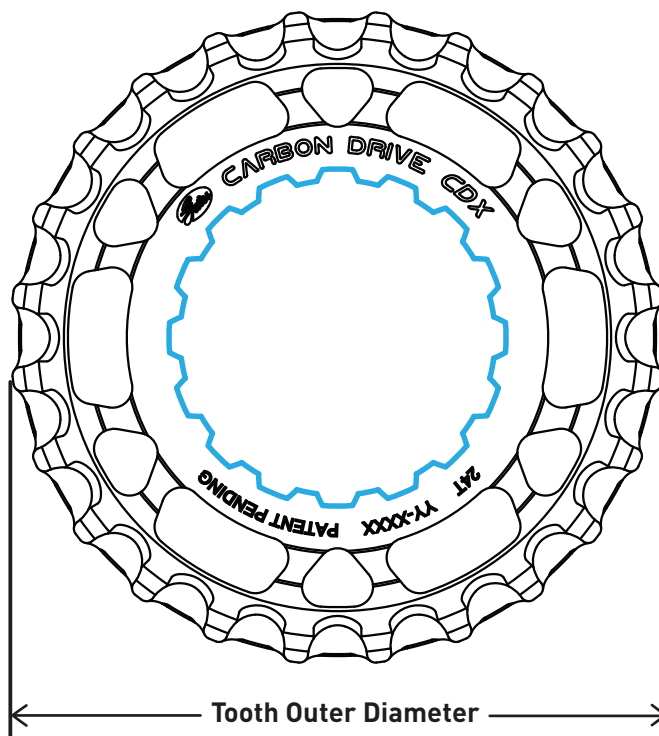

NOTE: For additional eBike integration information, download Gates eBike integration manual. GatesCarbonDrive.com/eBike



shim kit



CDX FRONT: BOSCH GEN2

Teeth	Part Number	Tooth O.D.	Mounting Web Thickness	Sprocket Width	Flange Offset Mount Surface	Flange Offset Centerline
22	CT1122BMN-K*	75.3	2.0	11	2.5	1.5
24	CT1124BMN-K*	82.3	2.0	11	2.5	1.5
26	CT1126BMN-K*	89.3	2.0	11	2.5	1.5
28	CT1128BMN-K*	96.3	2.0	11	2.5	1.5
22	CT1122BMN-0-R**	75.3	4.5**	11	8.2	6.0

* Must use shim kit and locknut provided by Gates. These part numbers includes the required shim kit and locknut.

** Rohloff-specific sprocket does not utilize shims.

Reference Gates Carbon Drive eBike Integration Manual for detailed information.



STEPS E6100 ASSEMBLY SELECTION CHART

REAR HUB BRAND	COMPATIBLE HUBS	BELTLINE	FRONT SPROCKET TEETH	CENTERED NODE ASSEMBLY PART NUMBER**	3MM OFFSET NODE ASSEMBLY PART NUMBER**	REAR SPROCKET TYPE	
Shimano	Inter 5E (Di2)	41.7MM	39	N/A	S4S6BM 39CDX -3/41.7 BG	YMN-D	
			42		S4S6BM 42CDX -3/41.7 BG		
			Nexus 8, Alfine 8/11 (Di2)	50	N/A	S4S6BM 50CDX -3/41.7 BG	XMN-D
				55		S4S6BM 55CDX -3/41.7 BG*	
	Inter 5E (Mechanical)	45.5MM	39	S4S6BM 39CDX -0/45.5 BG	S4S6BM 39CDX -3/45.5 BG	YMN-U	
			42	S4S6BM 42CDX -0/45.5 BG	S4S6BM 42CDX -3/45.5 BG		
			Nexus 8, Alfine 8/11 (Mechanical)	46	S4S6BM 46CDX -0/45.5 BG	S4S6BM 46CDX -3/45.5 BG	XMN-U
				50	S4S6BM 50CDX -0/45.5 BG	S4S6BM 50CDX -3/45.5 BG	
				55	S4S6BM 55CDX -0/45.5 BG*	S4S6BM 55CDX -3/45.5 BG	
	enviolo	enviolo CT, TR, SP, CA, CO (135/142mm OLD)	45.5MM	46	S4S6BM 46CDX -0/45.5 BG	S4S6BM 46CDX -3/45.5 BG	VMN
50				S4S6BM 50CDX -0/45.5 BG	S4S6BM 50CDX -3/45.5 BG		
55				S4S6BM 55CDX -0/45.5 BG*	S4S6BM 55CDX -3/45.5 BG		
enviolo SP, CA (148mm OLD)		48.7MM	46	S4S6BM 46CDX -0/48.7 BG	N/A		
			50	S4S6BM 50CDX -0/48.7 BG			
			55	S4S6BM 55CDX -0/48.7 BG			

For hubs or beltlines not listed, please contact your Gates Carbon Drive technical representative.

"BG" at end of Part Number specifies inclusion of an ISO compliant Black Guard. Alternatively "NG" would specify No Guard.

* Compatibility with "T" Touring Cover only. Interference may occur with "C" City Cover. Custom covers may eliminate this interference.

** Requires use of Gates spider assemblies.

Reference Gates Carbon Drive eBike Integration Manual for detailed information.

CDXTM CENTERTRACK

FRONT SPROCKETS

THE CENTERTRACK SYSTEM PROVIDES MAXIMUM DURABILITY AND MINIMUM WEIGHT FOR ALL ENVIRONMENTS AND BIKE TYPES

Higher tensile strength belt, a slimmer profile sprocket and improved dirt and debris-shedding abilities. Dirt and grime simply fall away, making CenterTrack technology ideal for muddy or snowy conditions. The slender profile sprockets allow for additional chainstay clearance - making it easy to integrate with the latest generation of internal gear hubs and frame designs.

4-BOLT 104 mm BCD



36

5-BOLT 130 mm BCD



36

PINION



37

FRONT SPROCKETS

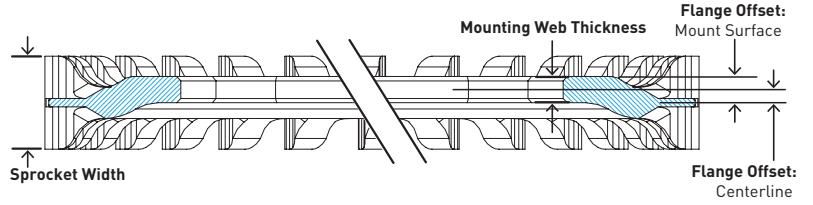
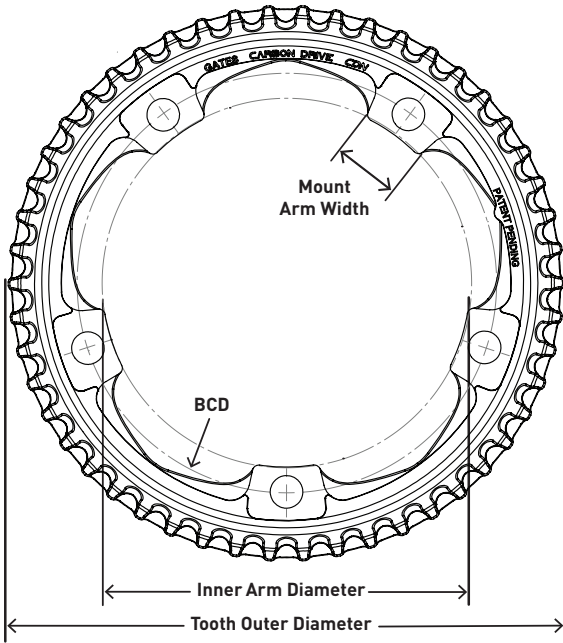

NOTE: If using the Gates Carbon Drive system in an application where impact to the belt is possible by external objects (large rocks, logs, etc.), it is highly recommended that the bicycle have a structural-type "bash" guard to protect the belt from impact.

CDX

Teeth	No. of Bolt Holes	Part Number	Mounting Arm Width	BCD	Inner Arm Diameter	Tooth O.D.	Mounting Web Thickness	Sprocket Width	Flange Offset Mount Surface	Flange Offset Centerline
39	4	CT11394AA	19	104	88.0	134.8	3.1	11	3.1	1.55
42		CT11424AA				145.2				
46		CT11464AA				159.3				
50		CT11504AA				173.2				
55		CT11554AA				190.7				
46	5	CT11465AA	18	130	114.5	159.3				
50		CT11505AA				173.2				
55		CT11555AA				190.7				
60		CT11605AA				208.2				
63		CT11635AA				218.7				
70	CT11705AA	243.2	17	130	114.5	173.2	3.85	2.3		
50	CT11505AA-D*	190.7								
55	CT11555AA-D*	190.7								
60	CT11605AA-D*	208.2								

* Shimano Alfine Di2 specific.

CDX:EXP

Teeth	No. of Bolt Holes	Part Number	Mounting Arm Width	BCD	Inner Arm Diameter	Tooth O.D.	Mounting Web Thickness	Sprocket Width	Flange Offset Mount Surface	Flange Offset Centerline
39	4	CT11394AA-7	19	104	88.0	134.8	3.1	11	3.1	1.55
46		CT11464AA-7				159.3				
50		CT11504AA-7				173.2				
55		CT11554AA-7				190.7				

CDN

Teeth	No. of Bolt Holes	Part Number*	Mounting Arm Width	BCD	Inner Arm Diameter	Tooth O.D.	Mounting Web Thickness	Sprocket Width	Flange Offset Mount Surface	Flange Offset Centerline
46	5	CT11465CN	20.9	130	114.5	159.3	3.6	11	3.6	1.8
50		CT11505CN				173.2				
55		CT11555CN				190.7				

* CDN front sprockets are only available pre-assembled to S150 or S100 crankssets.

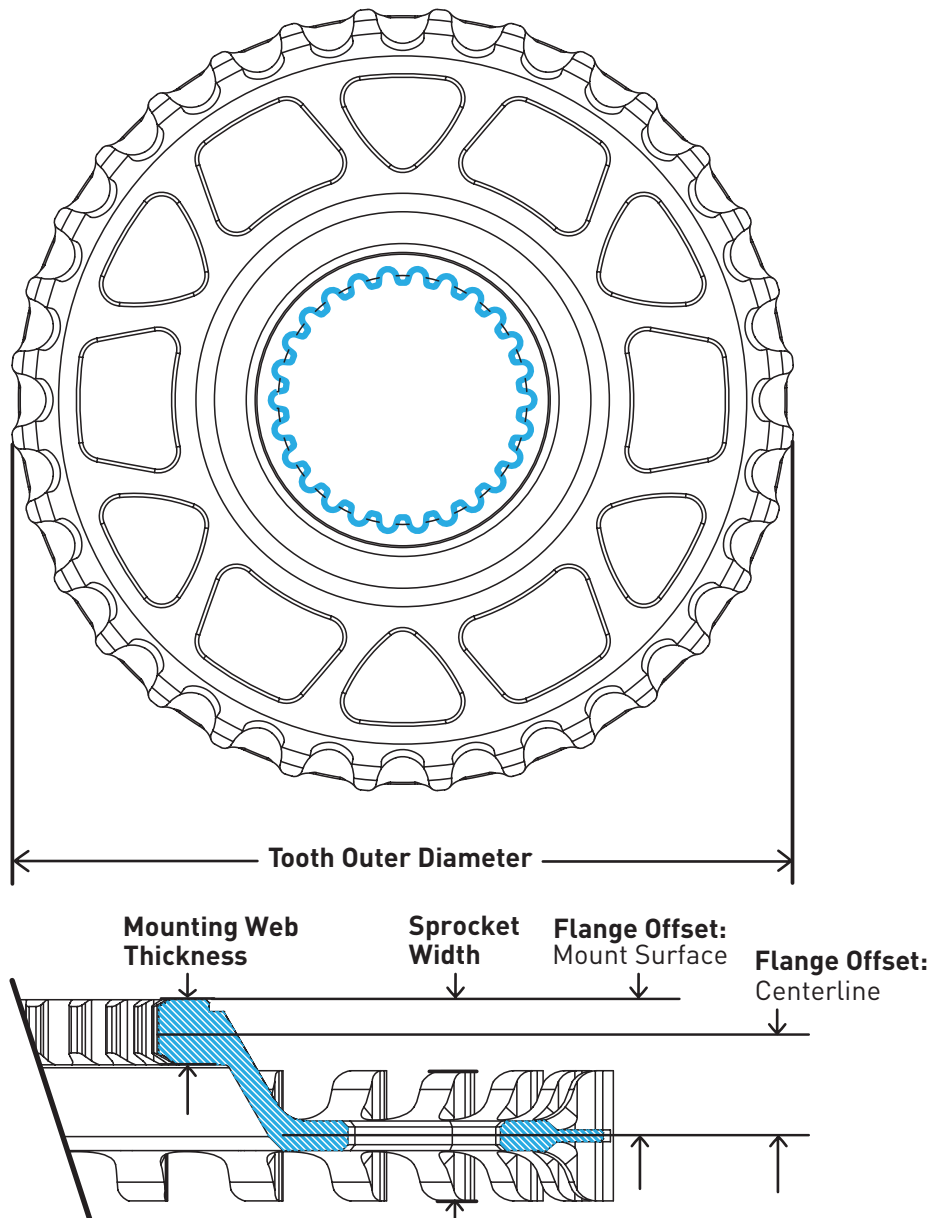

CDX

Teeth	Part Number	Tooth O.D.	Mounting Web Thickness	Sprocket Width	Flange Offset Mount Surface	Flange Offset Centerline
32	CT1132PMN	110.3	5.5	17	11.5	8.75

CDX:SL

Teeth	Part Number	Tooth O.D.	Mounting Web Thickness	Sprocket Width	Flange Offset Mount Surface	Flange Offset Centerline
32	CT1132PBA	110.3	5.5	17	11.5	8.75
39	CT1139PBA	134.8				

Note: Recommended rear sprocket see 9-spline page 40.

CDX™ CENTERTRACK

REAR SPROCKETS

SHIMANO



39

9-SPLINE



40

9-SPLINE 6-BOLT



41

ENVILO



42

ROHLOFF



43

STURMEY-ARCHER 3-LOBE



44

FREEWHEEL



45

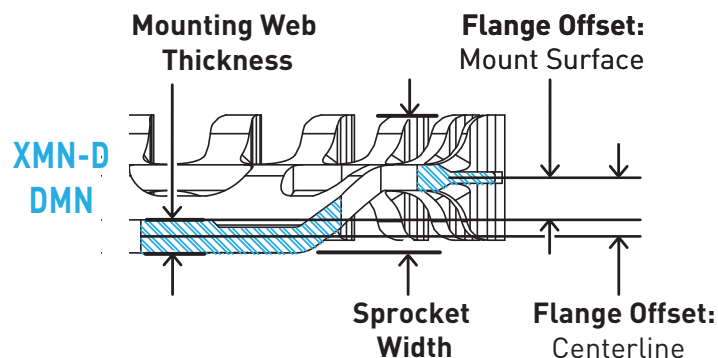
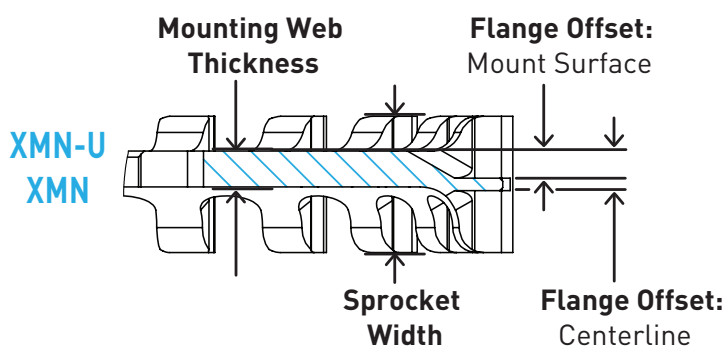
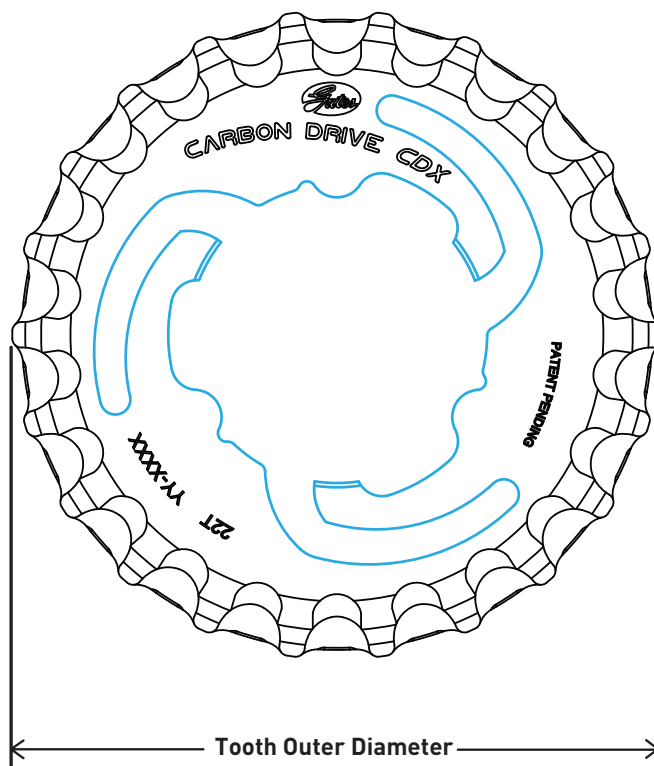

CDX REAR: SHIMANO SUREFIT 3-LOBE

Teeth	Part Number	Tooth Outer Diameter	Mounting Web Thickness	Sprocket Width	Flange Offset: Mount Surface	Flange Offset: Centerline
SUREFIT 3-LOBE						
22	CT1122XMN*	75.3	2.9	11.0	0.9	-0.55
24	CT1124XMN*	82.3				
26	CT1126XMN*	89.3				
SUREFIT 3-LOBE - UNIFIED OFFSET						
22	CT1122XMN-U	75.3	2.9	11.0	2.7	1.25
24	CT1124XMN-U	82.3				
26	CT1126XMN-U	89.3				
SHIMANO Di2						
28	CT1128DMN**	96.3	2.9	12.1	3.71	5.16
28	CT1128XMN-D***	96.3	2.9	11.0	1.60	3.05

* XMN sprocket type for 43.7mm beltline will be discontinued for MY20/MY21, replaced by XMN-U for 45.5mm beltline.

** DMN sprocket type for 39.8mm beltline will be discontinued for MY20/MY21, replaced by XMN-D for 41.7mm beltline.

*** Requires use of Shimano MU-UR500 Di2 system.

Note: MNM sprockets are no longer recommended for Shimano and SRAM 3-lobe hubs. Use XMN sprockets for optimal performance.

REAR SPROCKETS

9-SPLINE

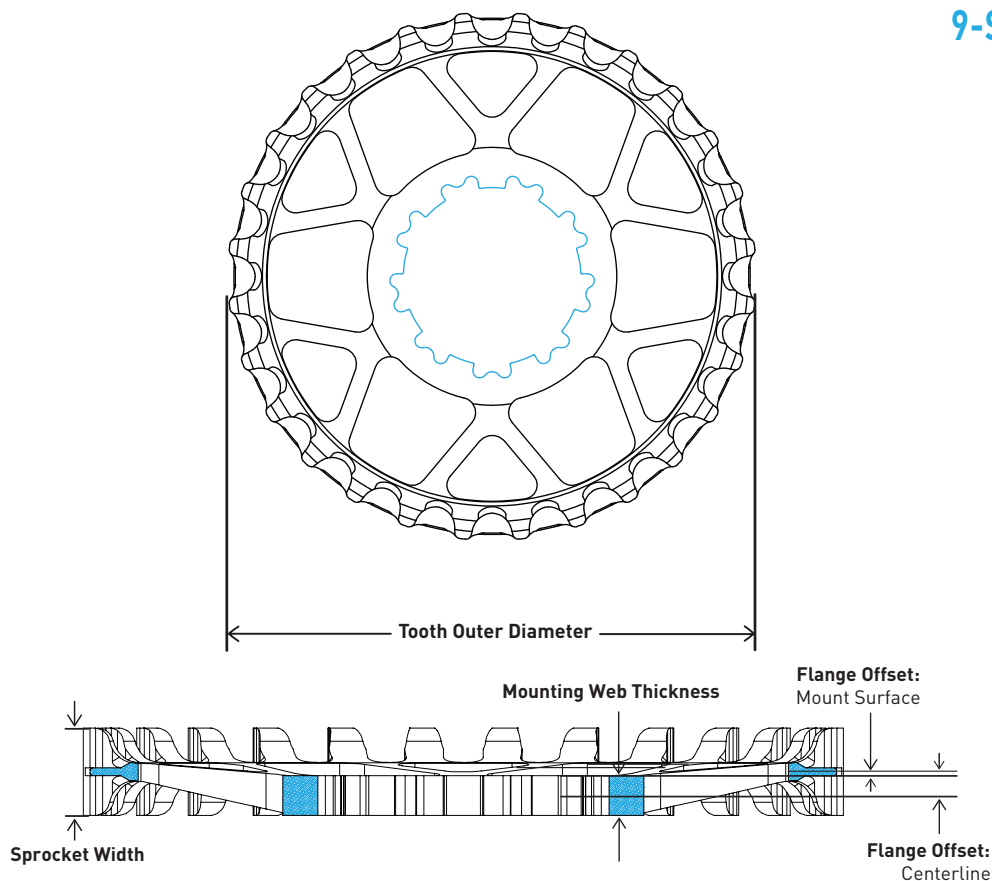

CDX REAR: 9-SPLINE

Teeth	Part Number	Tooth Outer Diameter	Mounting Web Thickness*	Sprocket Width	Flange Offset: Mount Surface	Flange Offset: Centerline
19	CT1119SMN	64.8	5.0	11.0	0.5	3.0
20	CT1120SMN	68.3				
21	CT1121SMN	71.8				
22	CT1122SMN	75.3				
23	CT1123SMN	78.8				
24	CT1124SMN	82.3				
26	CT1126SMN	89.3				
28	CT1128SMN	96.3				
30	CT1130SMN	103.3				
32	CT1132SMN	110.3				
34	CT1134SMN	117.3				

* Mounting Web Thickness has changed from 2.5 mm to 5.0 mm. Some stock of 2.5 mm remains. The belt line is unchanged but the removal of a spacer will be required.

CDX:SL REAR: 9-SPLINE

Teeth	Part Number	Tooth Outer Diameter	Mounting Web Thickness*	Sprocket Width	Flange Offset: Mount Surface	Flange Offset: Centerline
24	CT1124SBA	82.3	5.0	11.0	0.5	3.0
26	CT1126SBA	89.3				
28	CT1128SBA	96.3				
30	CT1130SBA	103.3				
32	CT1132SBA	110.3				
34	CT1134SBA	117.3				
39	CT1139SBA	134.8				

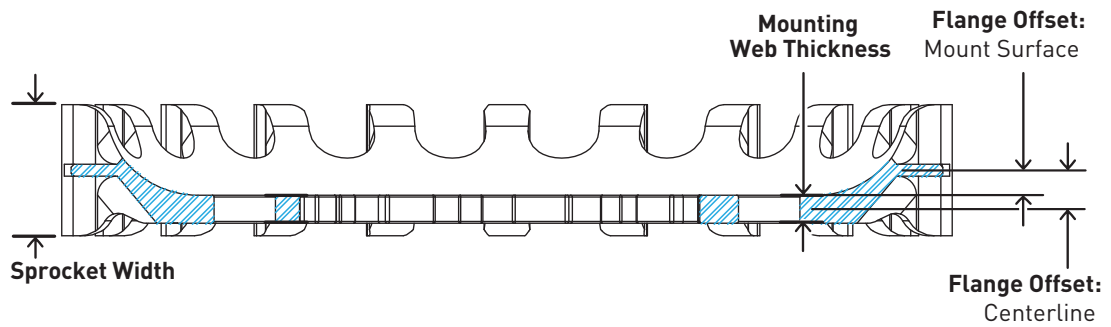
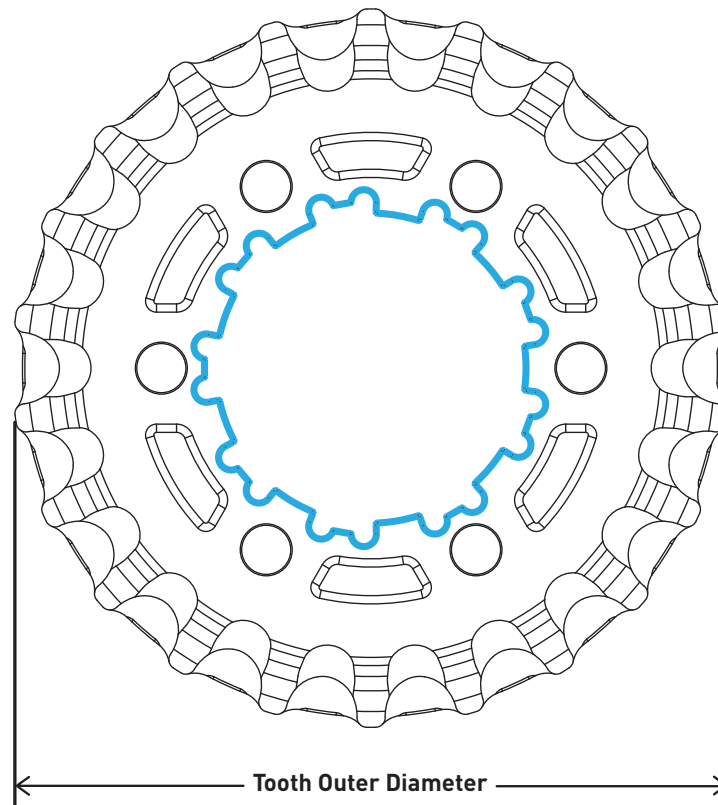

CDX REAR: 9-SPLINE 6-BOLT

Teeth	Part Number	Tooth Outer Diameter	Mounting Web Thickness	Sprocket Width	Flange Offset: Mount Surface	Flange Offset: Centerline
22	CT1122HMN	75.3	2.35	11	2.1	2.25

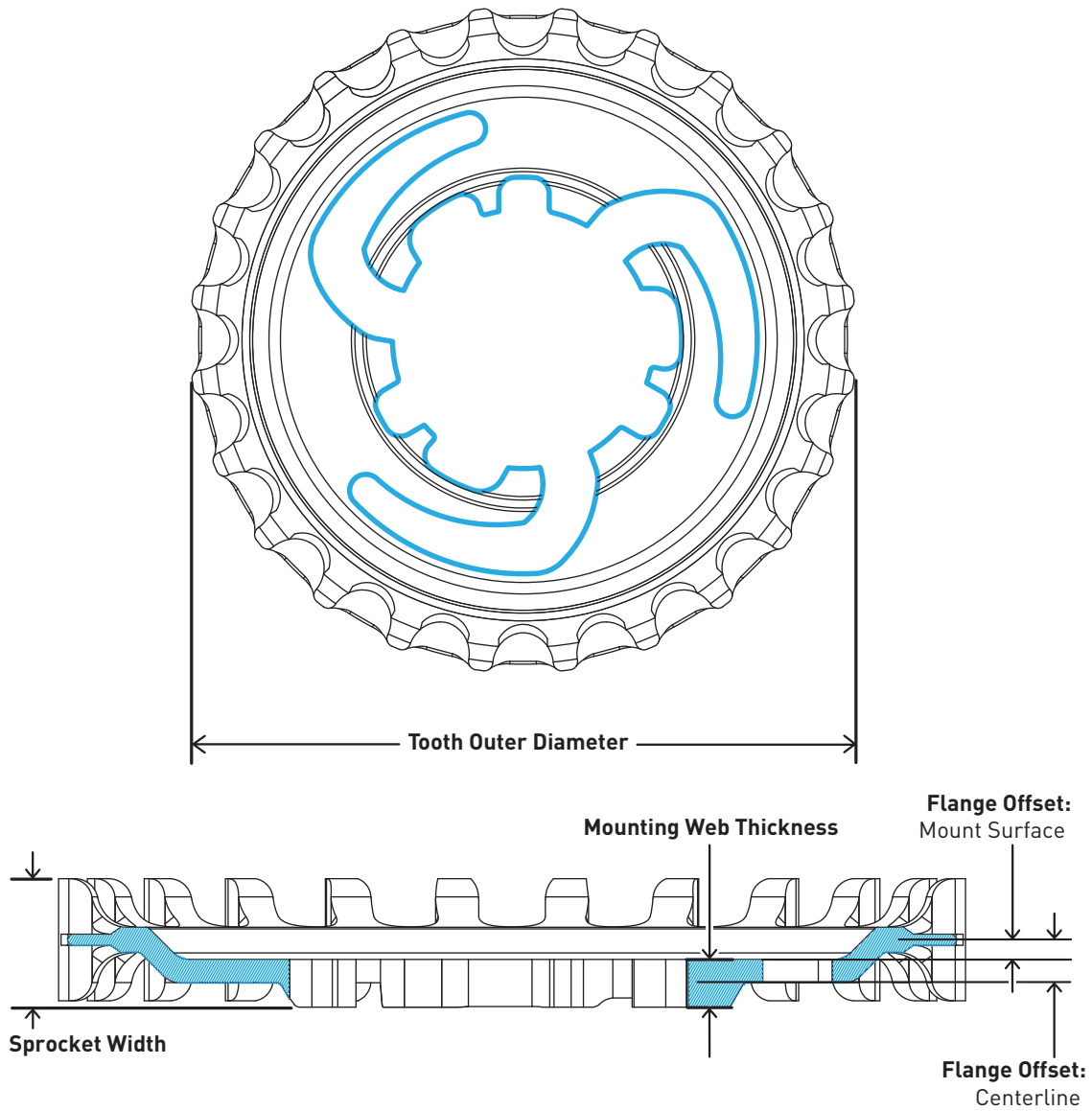

CDX REAR: ENVIOLLO SUREFIT

Teeth	Part Number	Tooth Outer Diameter	Mounting Web Thickness	Sprocket Width	Flange Offset: Mount Surface	Flange Offset: Centerline
22	CT1122VMN	75.3	4.3	11.6	1.78	3.93
24	CT1124VMN	82.3				
26	CT1126VMN	89.3				
28	CT1128VMN	96.3				

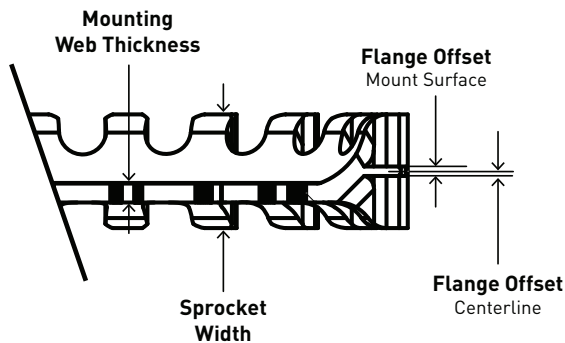
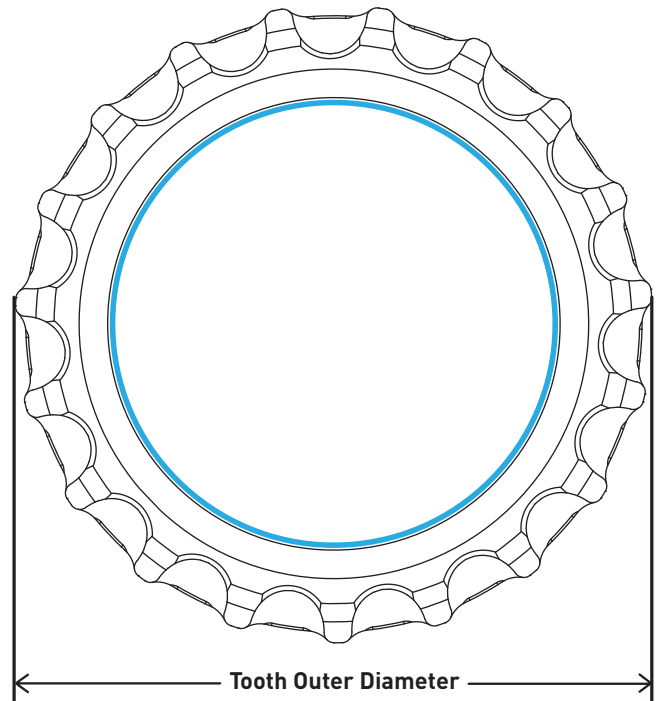
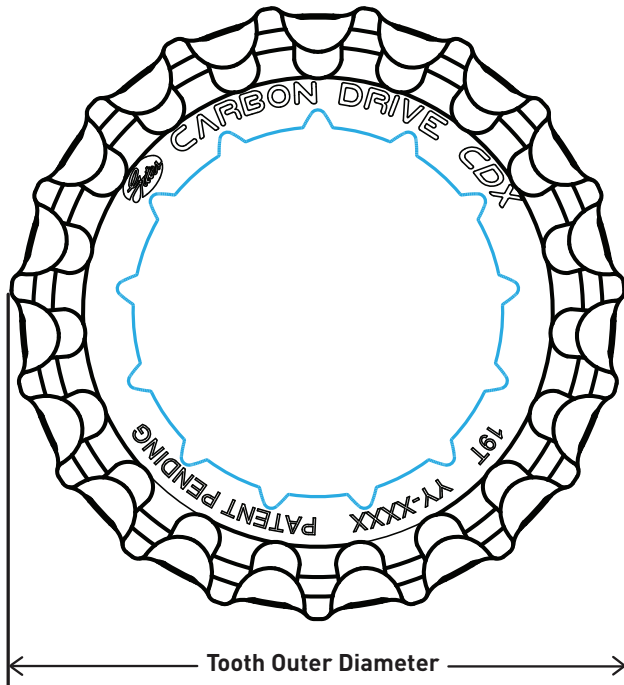

SPLINE

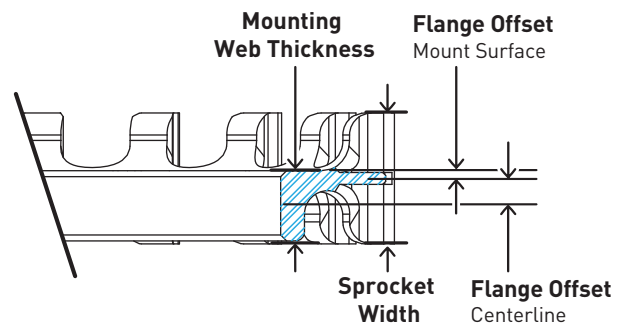

THREAD ON

CDX:EXP REAR

Teeth	Part Number	Tooth Outer Diameter	Mounting Web Thickness	Sprocket Width	Flange Offset: Mount Surface	Flange Offset: Centerline	Interface
ROHLOFF SPLINE							
19	CT1119RSMN	64.85	2.0	12	1.3	2.3	ROHLOFF SPLINE
20	CT1120RSMN	68.27					
22	CT1122RSMN	75.33					
ROHLOFF THREAD ON							
19	CT1119RMN-E	64.85	5.9	11	0.65	2.3	M46x6-6H (Six Start) Thread
20	CT1120RMN-E	68.27					
22	CT1122RMN-E	75.33					
24	CT1124RMN-E	82.26					

STURMEY-ARCHER

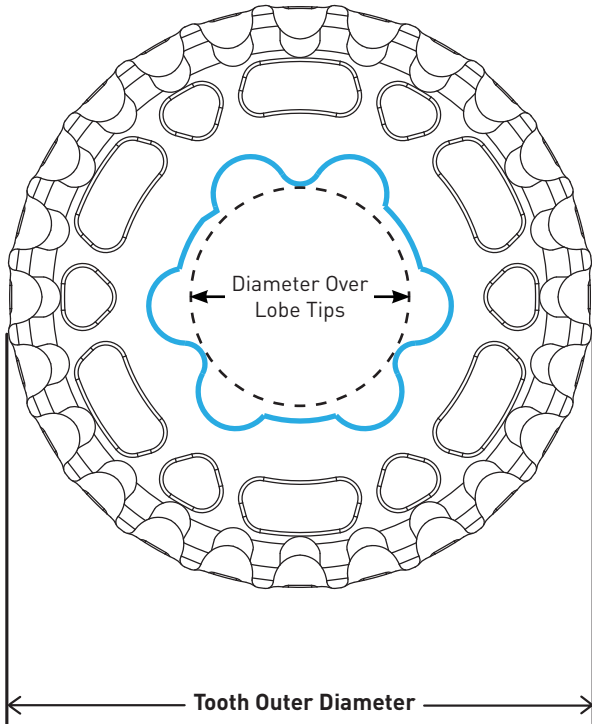

NMN

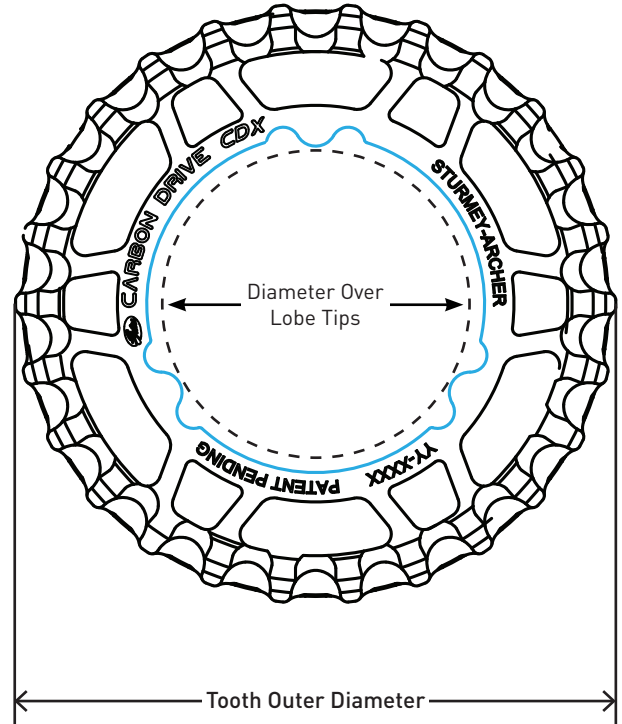

AMN

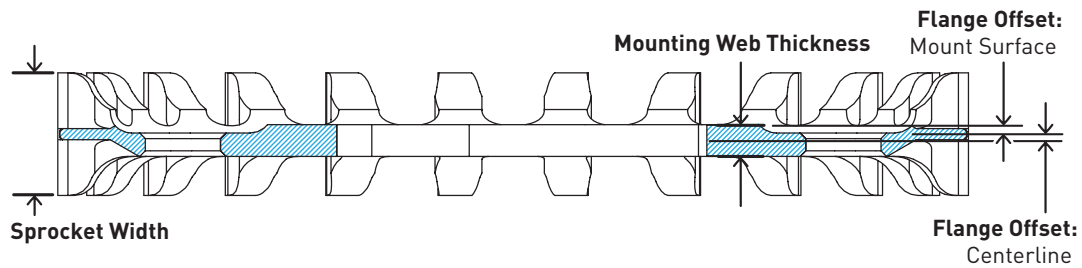

CDX REAR: STURMEY-ARCHER 3-LOBE

Teeth	Part Number	Tooth Outer Diameter	Diameter Over Lobe Tips	Mounting Web Thickness	Sprocket Width	Flange Offset: Mount Surface	Flange Offset: Centerline
22	CT1122NMN	75.3	31.9	2.9	11.0	0.9	0.55
24	CT1124NMN	82.3					0.95
26	CT1126AMN	89.3	46.9	3.1		0.60	

FREEWHEEL TRACK

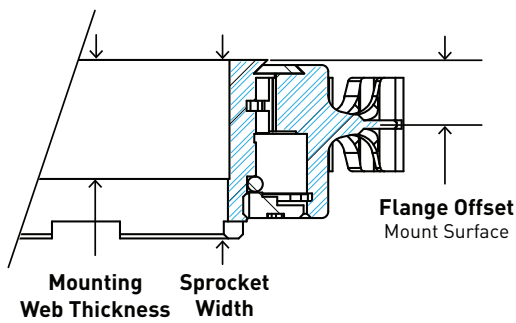
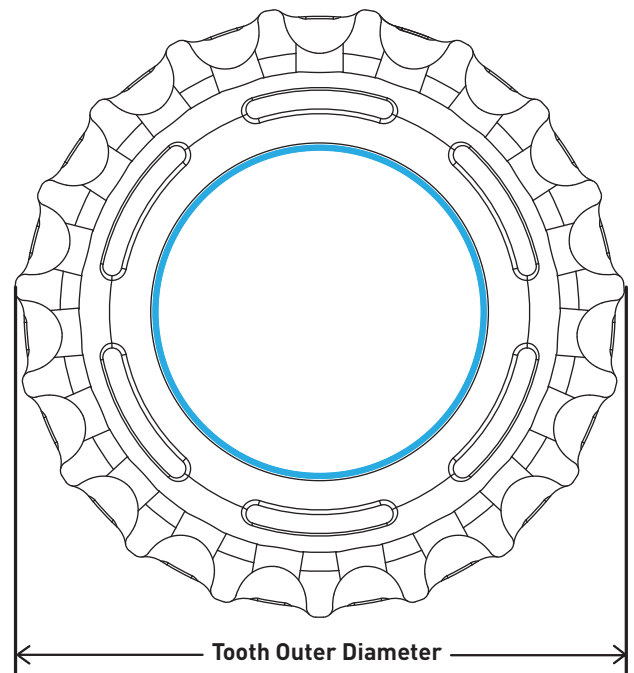
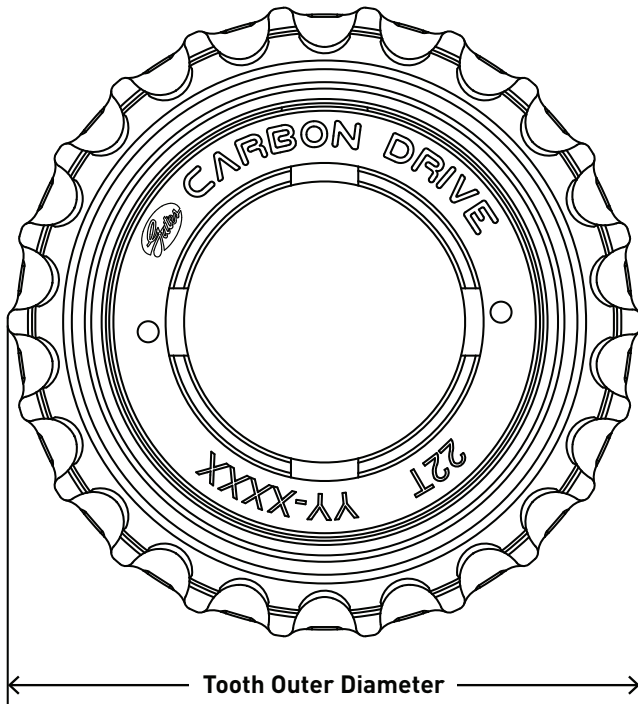

FREEWHEEL

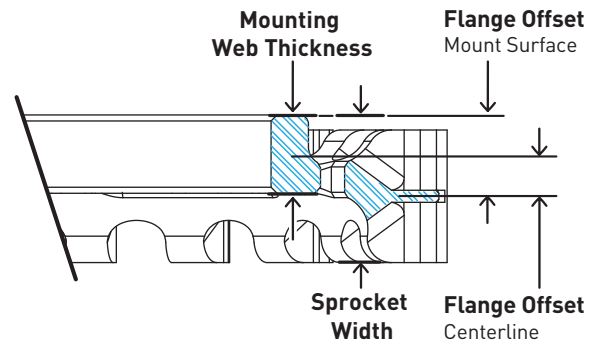

TRACK (THREAD ON)

CDX REAR

Teeth	Part Number	Tooth Outer Diameter	Mounting Web Thickness	Sprocket Width	Flange Offset: Mount Surface	Flange Offset: Centerline	Thread Count
FREEWHEEL							
22	CT1122WMN	75.3	14	18.5	6.90	N/A	1.370" x 24 RH
22	CT1122WSE			21			
TRACK (Thread On)							
19	CT1119FMN	64.8	6.5	12.5	6.75	3.5	1.370" x 24 RH
21	CT1121FMN	71.8					
22	CT1122FMN	75.3					

CARBON DRIVE™

..... BELTS



CDX™

CLEAN, SMOOTH, SIMPLE

No lube required = no grease stains. Sheds dirt and grime, and cleaning with water is easy. Just get on it and ride. No chain = no chain clatter. It's spooky quiet. A Gates Carbon Drive System weighs less than a chain. Lighter weight means higher performance. The instant engagement and smooth feel is unlike anything you've experienced before. You've got to ride it to believe it.

CDX

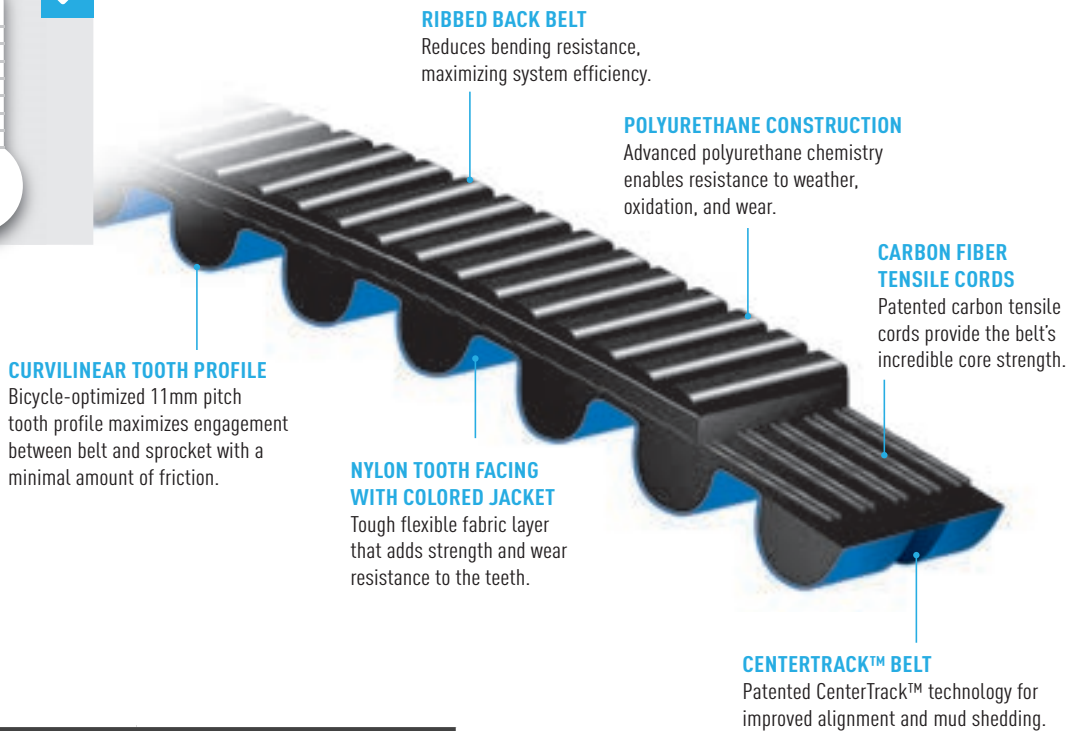
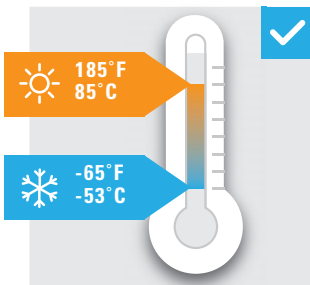

CDX CENTERTRACK BELT [12 mm width]

Teeth	Length	Description (See price list for color options)
108	1188 mm	11M-108T-12CT
111	1221 mm	11M-111T-12CT
113	1243 mm	11M-113T-12CT
115	1265 mm	11M-115T-12CT
118	1298 mm	11M-118T-12CT
120	1320 mm	11M-120T-12CT
122	1342 mm	11M-122T-12CT
125	1375 mm	11M-125T-12CT
128	1408 mm	11M-128T-12CT
130	1430 mm	11M-130T-12CT
132	1452 mm	11M-132T-12CT
151	1661 mm	11M-151T-12CT
158	1738 mm	11M-158T-12CT
166	1826 mm	11M-166T-12CT
168	1848 mm	11M-168T-12CT
174	1914 mm	11M-174T-12CT



CDN™ YOUR CARBON DRIVE NETWORK

Everything city riders want in a belt drive - clean, quiet, light, and strong performance, now at a lower price point.

Gates has specially engineered a new high modulus polymer belt with no-stretch carbon fiber tensile cords, and has developed a high-strength reinforced composite sprocket with CenterTrack™ design.

Together, the new Carbon Drive™ CDN™ System delivers the reduced weight and optimal performance you count on from Gates, as well as new belt drive opportunities for your higher-volume models.

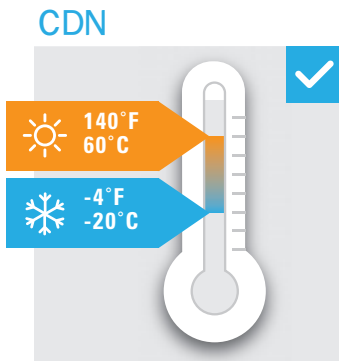

NOTE: The CDN System is not approved for use on mountain bikes, mid-drive eBikes or gear boxes, fixed gear bikes, or high mileage trekking/touring bikes.

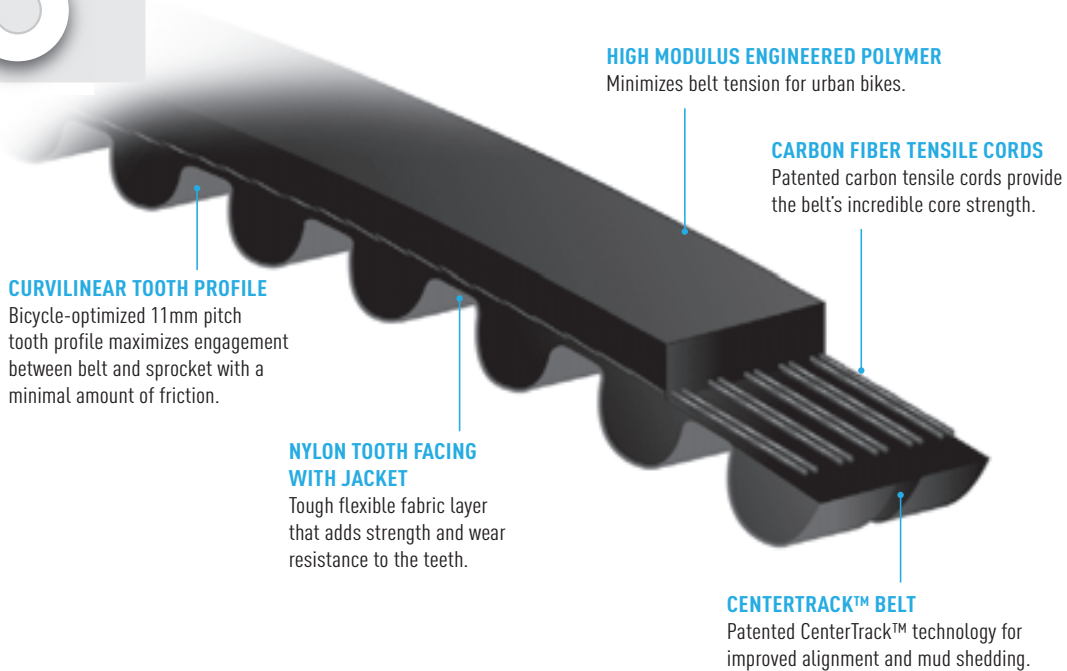

CURVILINEAR TOOTH PROFILE
Bicycle-optimized 11mm pitch tooth profile maximizes engagement between belt and sprocket with a minimal amount of friction.

NYLON TOOTH FACING WITH JACKET
Tough flexible fabric layer that adds strength and wear resistance to the teeth.

HIGH MODULUS ENGINEERED POLYMER
Minimizes belt tension for urban bikes.

CARBON FIBER TENSILE CORDS
Patented carbon tensile cords provide the belt's incredible core strength.

CENTERTRACK™ BELT
Patented CenterTrack™ technology for improved alignment and mud shedding.

CDN CENTERTRACK BELT [12 mm width]		
Teeth	Length	Description [BLACK only]
111	1221 mm	11M-111T-12CT CDN
113	1243 mm	11M-113T-12CT CDN
115	1265 mm	11M-115T-12CT CDN
118	1298 mm	11M-118T-12CT CDN
120	1320 mm	11M-120T-12CT CDN
122	1342 mm	11M-122T-12CT CDN



CDX™ TANDEM PRODUCTS



CDX CENTERTRACK BELT [12 mm width]

Teeth	Length	Description [See price list for color options]
250	2000 mm	8M-250T-12CT

NOTE: 11mm belt sizes now enable use of standard CDX front sprockets for tandem timing applications.

CDX TANDEM SPROCKETS*

Teeth	No. of Bolt Holes	Part Number	Mounting Arm Width	BCD	Inner Arm Diameter	Tooth O.D.	Mounting Web Thickness	Sprocket Width	Flange Offset Mount Surface	Flange Offset Centerline
66	5	CT08665AA	21	130	114.5	166.3	3.1	11	3.1	1.55
69		CT08695AA				174.2				
74		CT08745AA				186.8				

* Tandem sprockets and Front sprockets are not interchangeable. Tandem sprockets have an 8mm tooth pitch, while Front sprockets have an 11mm tooth pitch.

CARBON DRIVE™

..... SPECIFICATIONS



BELT LINE SPECIFICATION

GENERAL SAFETY

HANDLING THE BELT

CARBON DRIVE CARE

PROPER ALIGNMENT

***REAR WHEEL REMOVAL
& INSTALLATION***

REPLACE WHEN WORN

SPROCKET TOOLS

TROUBLESHOOTING

GLOSSARY

WARRANTY

CONTACTS

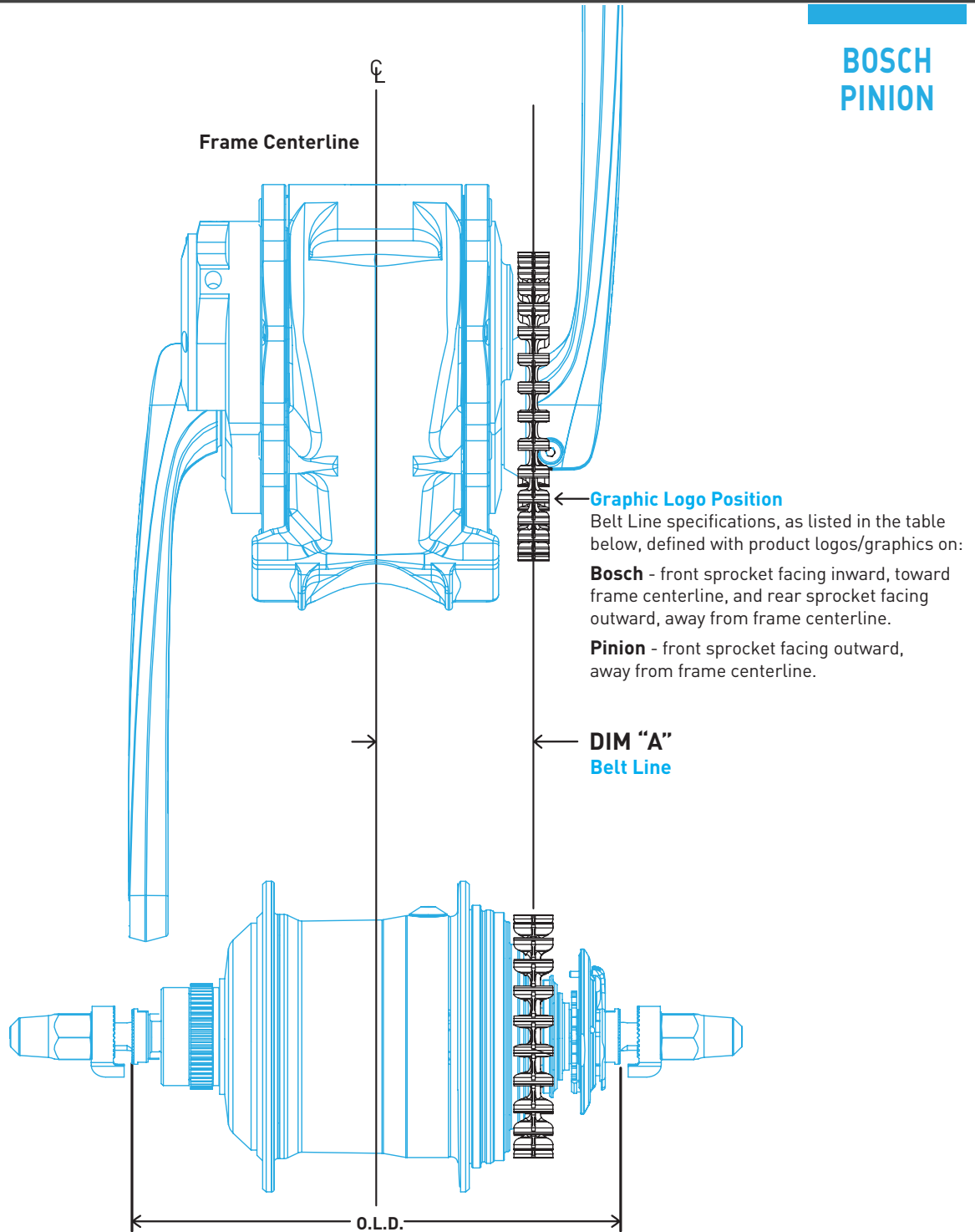

CDX MID-MOUNT DRIVE SYSTEMS: BOSCH/PINION

Manufacturer	Description	Model Number	DIM "A" Belt Line
Pinion	Gearbox	P-Line	56.0
		C-Line	52.0
Bosch	e-Bike Drive Unit	GEN2 w/ Alfine	43.6
		GEN2 w/ enviolo	45.5

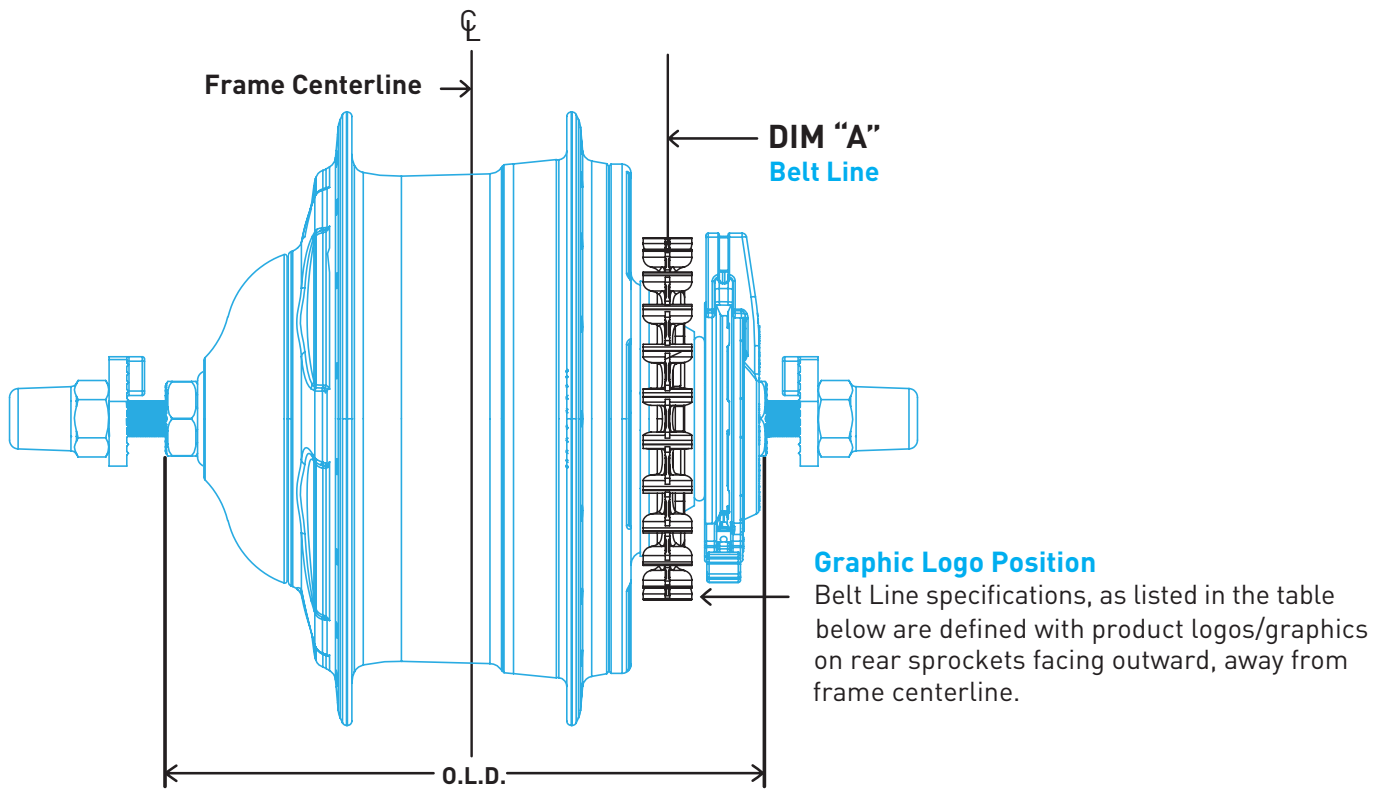

CDX/CDN INTERNAL GEAR HUB BELT LINE: ENVILO

Manufacturer	Hub Description	OLD	Brake Type	Hub Product Numbers	DIM "A" Belt Line	Rear Sprocket Carbon Drive Group
enviolo	CVP	135/142	Disc, Rim, Roller	enviolo CT, TR, SP, CA, CO	45.5	VMN
		148	Disc, Rim	enviolo SP, CA	48.7	

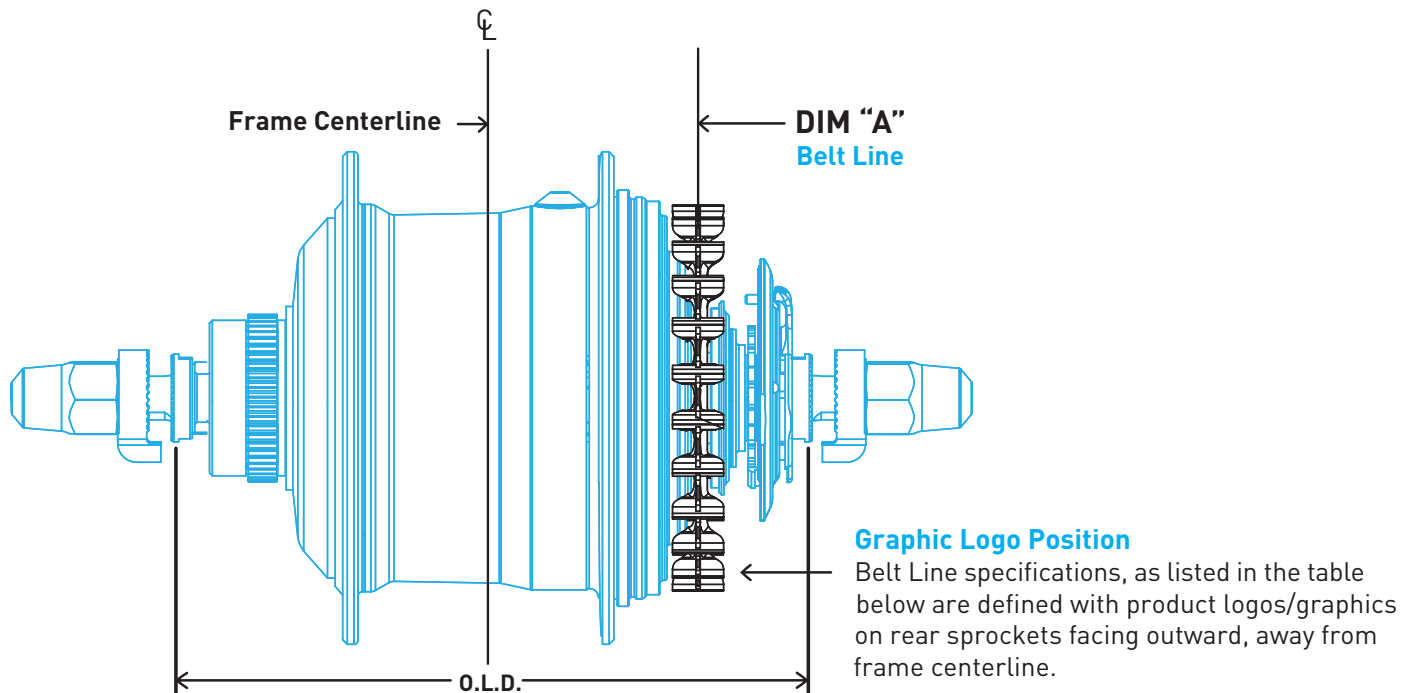

CDX/CDN INTERNAL GEAR HUB BELT LINE: SHIMANO

Manufacturer	Hub Description	OLD	Brake Type	Hub Product Numbers	DIM "A" Belt Line	Rear Sprocket Carbon Drive Group	
Shimano	Alfine 11	135	Disc	SG-S700	43.7* / 45.5	XMN* / XMN-U	
	Alfine 11 Di2**			SG-S705	41.7	XMN-D	
	Alfine 8			SG-S7001-8	43.7* / 45.5	XMN* / XMN-U	
	Alfine 8 Di2**			SG-S7051-8	41.7	XMN-D	
	Inter 5E			SG-S7000-5	45.5	YMN-U	
	Inter 5E Di2			SG-S7050-5	41.7	YMN-D	
	Nexus 3	127	Coaster	SG-3C41	41.2*	XMN*	
		120		SG-3C41	42.7*		
		Nexus 3****	135	Disc	SG-3D55	43.7	NMN
		Nexus 7	130	Roller	SG-C3000-7R	42.1*	XMN*
			127	Coaster	SG-C3000-7C	43.3*	
		Nexus 8 ***	135	Disc	SG-C3001-7D	45.7	XMN-U
					SG-C6001-8D, SG-C6001-8CD		43.7* / 45.5
			132	Roller, Rim	SG-C6011-8R, SG-C6001-8R, SG-C6011-8V, SG-C6001-8V	44.6*	XMN*
			132.3	Coaster	SG-C6001-8C	44.8*	XMN*
	Nexus 8 Di2**	135	Disc, Roller, Coaster	SG-C6061-8R, SG-C6061-8C, SG-C6061-8D, SG-C6061-8CD	41.7	XMN-D	

* XMN sprocket type for 43.7mm beltline will be discontinued for MY20/MY21, replaced by XMN-U for 45.5mm beltline.

** Requires use of Shimano Di2 motor MU-UR500.

*** For 22T sprockets on all mechanical 8-speed hub combinations, customers should order "Right hand dust cap B for INTER-8".

**** 6-lobe driver is not compatible with XMN sprockets.

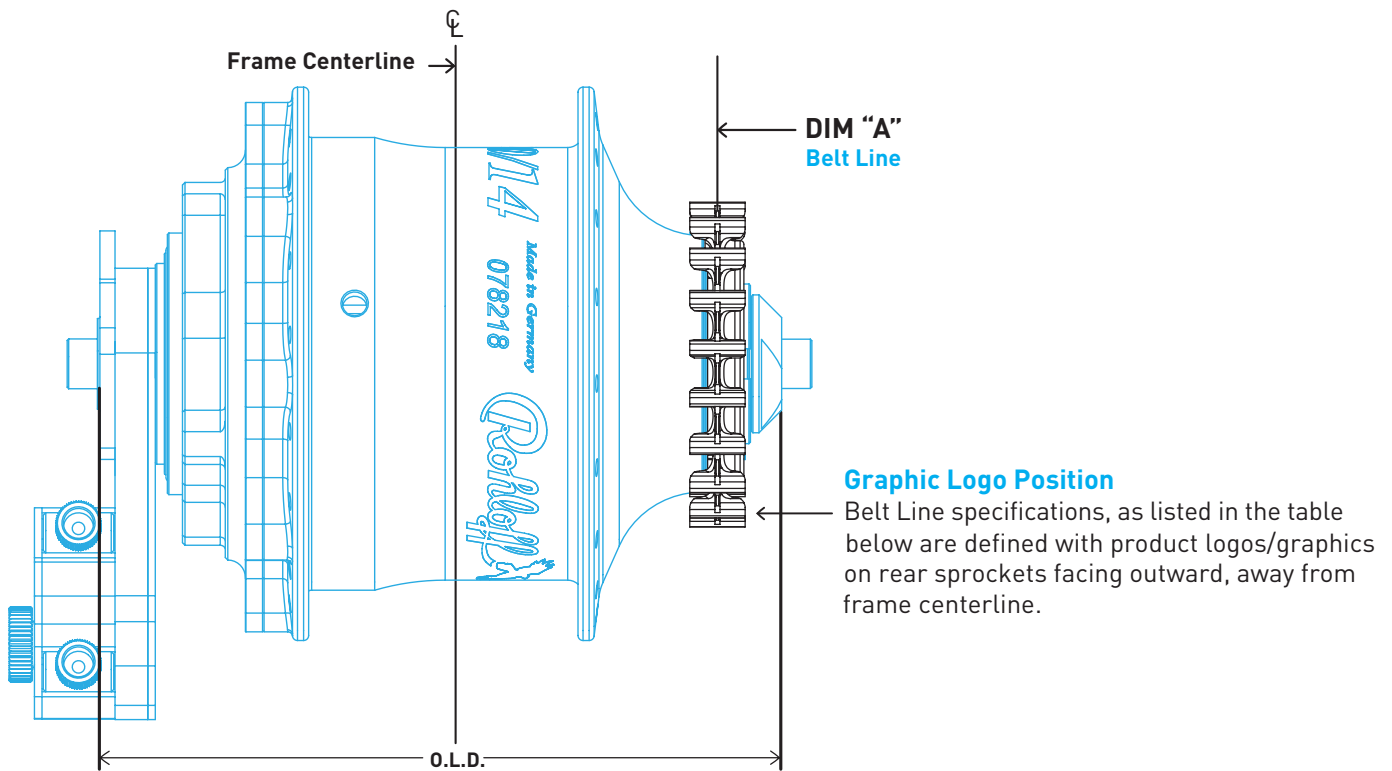

CDX INTERNAL GEAR HUB BELT LINE: ROHLOFF

Manufacturer	Hub Description	OLD	Brake Type	Hub Product Numbers	DIM "A" Belt Line	Rear Sprocket Carbon Drive Group
Rohloff	SpeedHUB	135/142	Disc, Rim	500/14	54.7	RMN-E, RSMN
		148			51.7	
		177		XL 500/14	72.2	

Note: Rohloff integrations require a snubber. See Gates® Rohloff specific manual for additional information.

WARNING

Read this information before using, replacing, or installing the Gates Carbon Drive belt. Improper installation, adjustment, alteration, service, or maintenance can result in property damage and serious bodily injury, including death. Refer to the Gates Carbon Drive Owner's Manual for assistance or consult with a cycling professional for further information.



GENERAL SAFETY

Handling the Belt

Do not crimp, twist, backbend, invert, bundle or zip tie the belt. Do not use the belt as a strap wrench or chainwhip. Do not roll on or pry on the belt. See page 56.

Gates requires a hand brake as the primary braking system Belt Tension and Drive Alignment

Proper tension and drive alignment is key to optimal performance.

- Lack of belt tension can lead to “skipping”. Too much tension can damage other components and increase the wear of your Carbon Drive System.
- Signs of a misaligned drive include, but are not limited to, noise, premature belt or sprocket wear, belt walk-off. Detailed information and schematics can be found in this manual. You can also contact us directly via email at CarbonDrive@Gates.com.

Care for your Carbon Drive

- Wash with water to remove debris.
- Acceptable temperature range for CDX and CDC belts is -65°F (-53°C) to +185°F (+85°C).
- Acceptable temperature range for the CDN system is -4°F (-20°C) to +140°F (+60°C).
- Do not lubricate.
- If your bike is equipped with a snubber, the snubber must not be in contact with the belt.
- This is a drive system – it is imperative to keep bodily parts and clothing away from the drive while in motion.

Improper installation, adjustment, alteration, service, or maintenance can result in property damage and serious bodily injury, including death. Refer to the Owner's Manual for assistance or consult with a cycling professional for further information. www.GatesCarbonDrive.com/OwnersManual

HANDLING THE BELT

Gates Carbon Drive™ Belts are extremely durable and offer long life when properly handled. However, caution must be used before and during installation to avoid damaging the carbon tensile cords that make up the backbone of the belt's strength. Excessive bending and twisting creates crimps which can lead to belt breakage under high load.

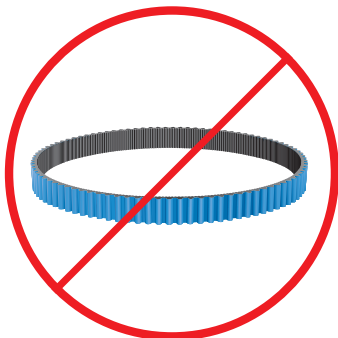
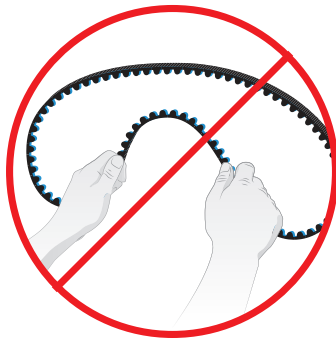
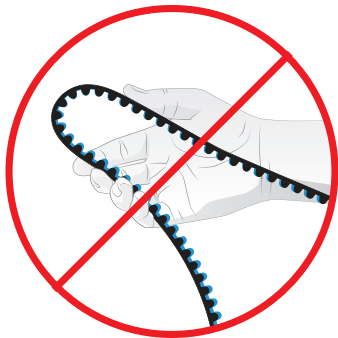

DO NOT ROLL ON



DO NOT PRY ON



Use Caution. Although clean of grease, belt drives can still catch pants, skirts or loose clothing. Installation of a belt guard is recommended.

CARE FOR YOUR CARBON DRIVE

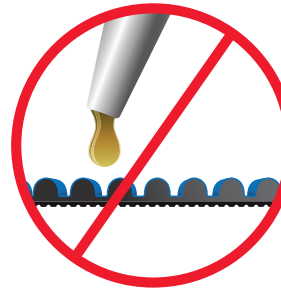
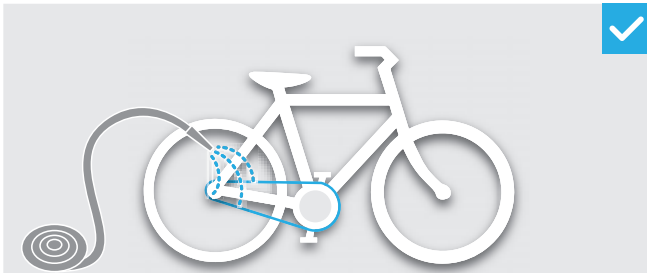
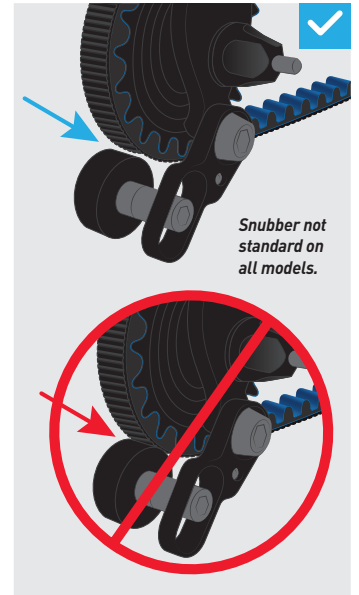
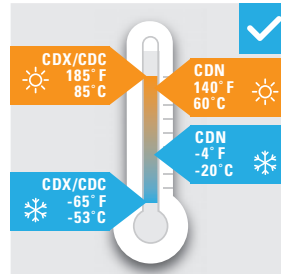
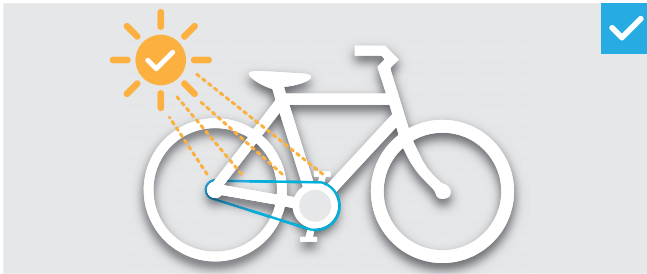

PROPER ALIGNMENT

Alignment is critical, and depending on the particular bike and setup, spacers may be used to ensure proper alignment. Sprockets that are out of alignment can cause noise, wear, or belt walk-off. Belt alignment refers to the parallel (side to side) and angular (toe in - toe out) alignment of the belt between the front and rear sprocket positions. Proper alignment is critical in order to maintain proper system performance.

See page 10 for more information.

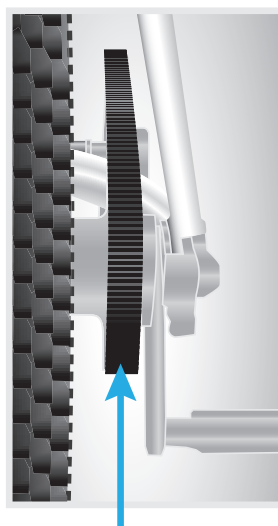

PROPER ALIGNMENT

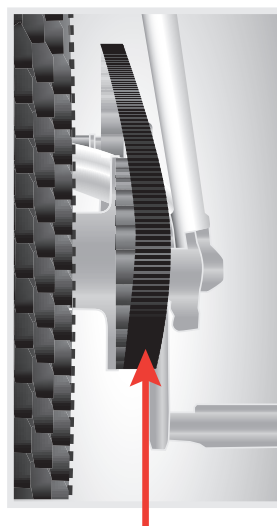

CDC SPROCKETS ARE NOT ALIGNED

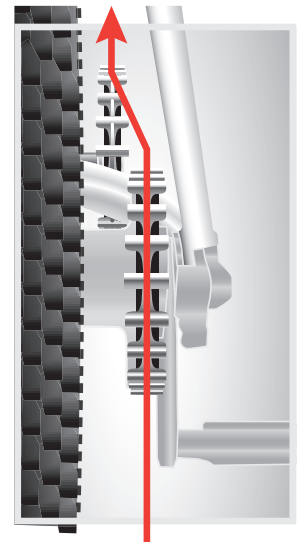

CDX SPROCKETS ARE NOT ALIGNED

REAR WHEEL REMOVAL & INSTALLATION

SEE BIKE MANUFACTURER FOR ADDITIONAL WHEEL REMOVAL DETAILS

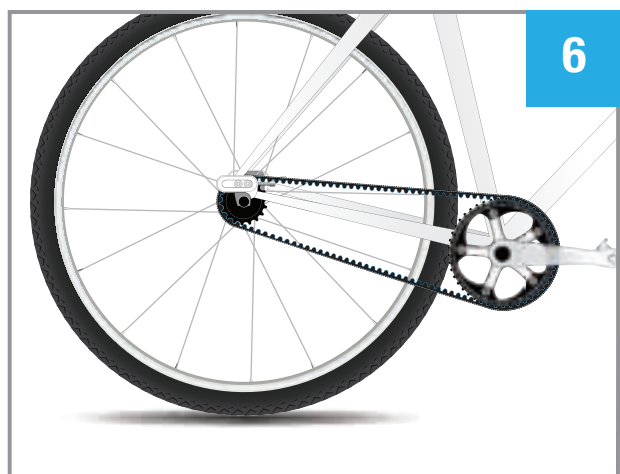
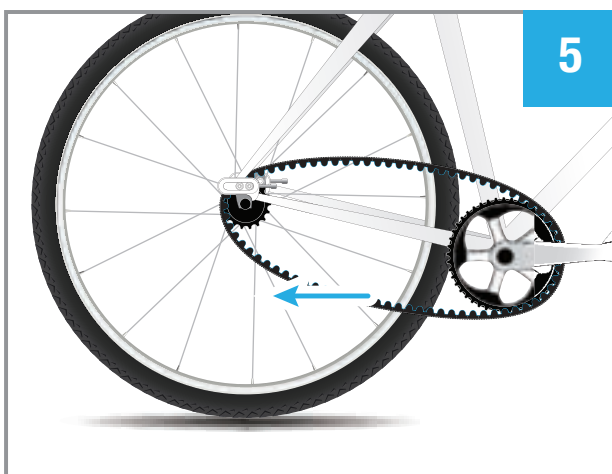
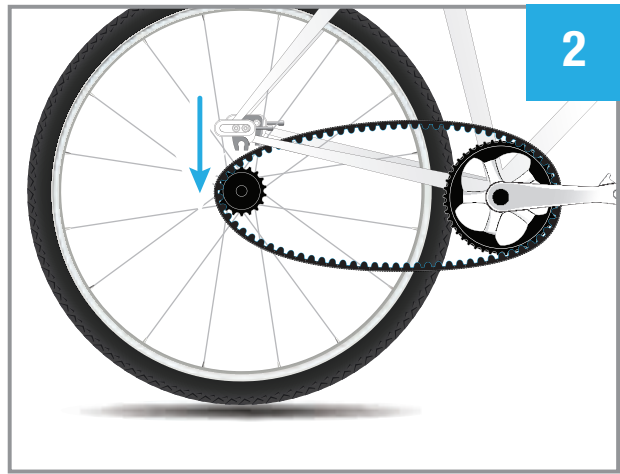
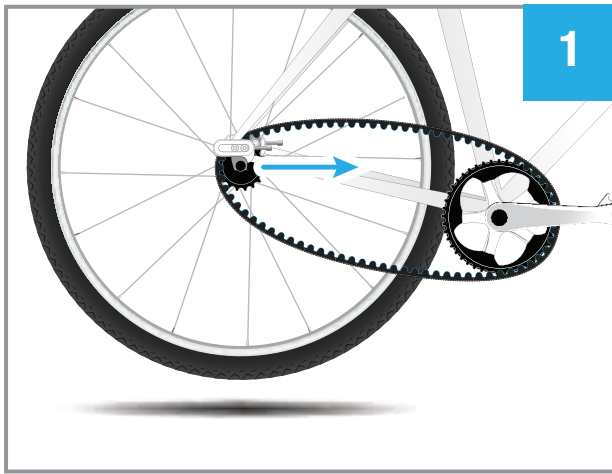

REPLACE WHEN WORN

GATES CARBON DRIVE™ BELTS AND SPROCKETS ARE EXTREMELY DURABLE AND BUILT TO OFFER A LONG LIFE, BUT THEY DO WEAR AND TEAR OVER TIME. PERIODICALLY, CAREFULLY INSPECT YOUR BELT AND SPROCKETS FOR SIGNS OF DETERIORATION:



✓ This belt is in **excellent condition**. Loss of blue color does NOT indicate wear.

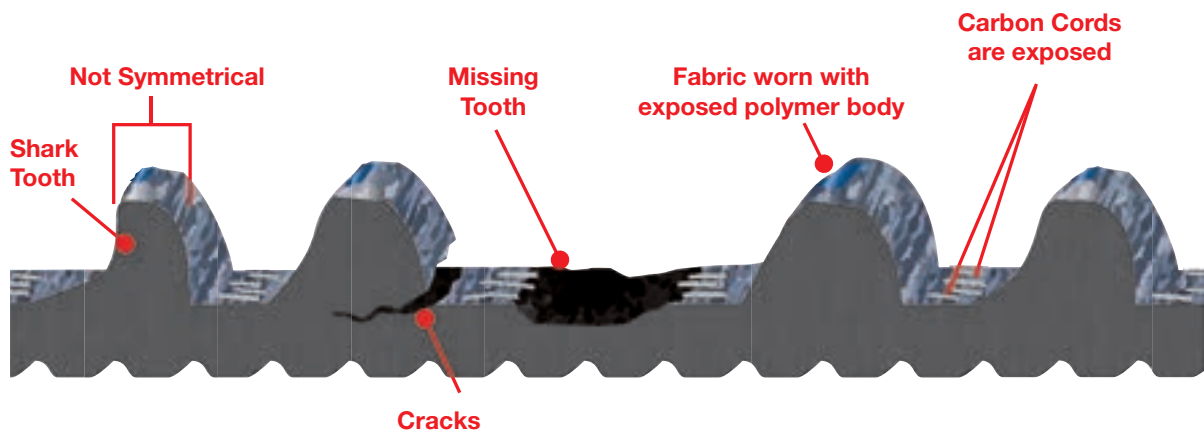

⊘ **Replace** your belt when it shows these signs of wear and tear.

WARNING: Using a worn or damaged Carbon Drive belt or failing to properly inspect the Carbon Drive belt before each usage can result in property damage and serious bodily injury, including death.

Worn CDC Sprocket Teeth



⊘ **Replace** your CDC sprockets when the teeth become worn as shown in the illustration above.

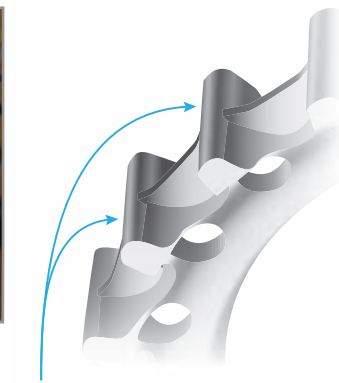

✓ This CDX Sprocket is in **excellent condition**.

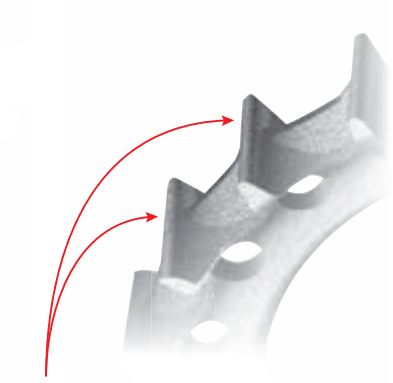

⊘ **Replace** your CDX sprockets when the teeth become worn.

GATES SPROCKET TOOLS

FOR REMOVAL OF REAR SPROCKET AND LOCKRING.

GATES SPROCKET WRENCH

The Gates Sprocket Wrench is recommended for removing the rear sprocket. Be sure to follow all handling instructions for removing the Gates Carbon Drive belt: Do not crimp, twist, backbend, invert, bundle or zip tie the Carbon Drive belt. Do not use the Carbon Drive belt as a strap wrench or chainwhip. Do not roll or pry on the Carbon Drive belt.

Gates product # 7468-0007



SUREFIT™ INSTALLATION TOOL

Aids in the installation of Shimano and Enviolo SureFit sprockets.

Gates product #7468-0999



TROUBLESHOOTING

Note: This is not a comprehensive list of possible issues. Please contact us for more information.

Symptom	Possible Causes	Corrective Action
Belt Running Off Sprockets	Mis-alignment of the drive system	<ul style="list-style-type: none"> • Check to make sure sprockets are properly aligned • Verify the correct amount of spacers have been used for the rear sprocket • Check to make sure the belt is not being pinched between sprocket flanges • Realign drive system and tension belt
	Improper belt tension	<ul style="list-style-type: none"> • Check to see if the rear wheel or dropout has moved • Check to see if the tensioning device has been affected • Reposition rear wheel in dropouts • Re-tension the belt and measure using an approved tool
	Rear wheel has moved in dropout or sliding dropout has moved	<ul style="list-style-type: none"> • Reposition rear wheel in dropouts • Re-tension the belt
	Chainring bolts coming loose	<ul style="list-style-type: none"> • Tighten chainring bolts
	Cassette lockring or snap ring coming loose	<ul style="list-style-type: none"> • Tighten cassette lockring • Verify correct number of spacers
	Excessive mud or debris in the drive system	<ul style="list-style-type: none"> • Clean mud or debris from the drive system • Belts that have been derailed may have been damaged, and should be replaced
	System damaged or worn	<ul style="list-style-type: none"> • Inspect sprockets and belt. Replace if needed
Belt Tooth Jumping on Sprockets	Improper belt tension	<ul style="list-style-type: none"> • Adjust tension and measure using an approved tool
	Belt system has lost its tension	<ul style="list-style-type: none"> • Check to see if the rear wheel or dropout has moved • Check to see if the tensioning device has been affected • Reposition rear wheel in the dropouts • Re-tension the belt and measure using an approved tool
	Rear wheel or sliding dropout has moved	<ul style="list-style-type: none"> • Reposition rear wheel in dropouts • Re-tension the belt
	Worn sprocket	<ul style="list-style-type: none"> • Replace sprocket and inspect belt for wear
	System damaged or worn	<ul style="list-style-type: none"> • Inspect sprockets and belt. Replace if needed

TROUBLESHOOTING

Symptom	Possible Causes	Corrective Action
Belt Tooth Wear	Excessive debris in drive system	<ul style="list-style-type: none"> • Clean any debris from sprocket and belt
	Improper belt tension	<ul style="list-style-type: none"> • Check to see if the tensioning device has been affected • Reposition rear wheel in dropouts • Re-tension the belt and measure using an approved tool
	Mis-alignment of the drive system	<ul style="list-style-type: none"> • Check to make sure the sprockets are properly aligned • Verify the correct amount of spacers have been used for the rear sprocket • Check to make sure the belt is not being pinched between the sprocket flanges • Realign drive system and tension belt, measure using an approved tool
	Worn sprocket	<ul style="list-style-type: none"> • Replace sprocket
	Damaged sprocket teeth	<ul style="list-style-type: none"> • Replace sprocket
	Sprocket flange damage	<ul style="list-style-type: none"> • Replace sprocket
	Worn or damaged belt	<ul style="list-style-type: none"> • Replace belt
Belt Squeaking	Mis-alignment of the drive system	<ul style="list-style-type: none"> • Check to make sure sprockets are properly aligned • Verify the correct amount of spacers have been used for the rear sprockets • Check to make sure the belt is not being pinched between the sprocket flange • Realign drive system and tension belt, measure using an approved tool
	Improper belt tension	<ul style="list-style-type: none"> • Check to see if the rear wheel or dropout has moved • Check to see if the tensioning device has been affected • Reposition rear wheel in dropouts • Re-tension the belt and measure using an approved tool
	Bent sprocket flange	<ul style="list-style-type: none"> • Replace sprocket
	Worn sprocket	<ul style="list-style-type: none"> • Replace sprocket
	Chainring bolts coming loose	<ul style="list-style-type: none"> • Tighten chainring bolts
	Dry, Dusty Conditions	<ul style="list-style-type: none"> • Particular environments have been known to cause a squeak • Applying dry silicon to a clean belt can help

TROUBLESHOOTING

Symptom	Possible Causes	Corrective Action
Broken Belt	Improper belt handling, storage or installation	<ul style="list-style-type: none"> Follow Owner's Manual belt handling instructions and installation tips gatescarbondrive.com/ownersmanual Never roll or pry belt onto sprockets Replace belt
	Debris or object in drive system	<ul style="list-style-type: none"> Clean debris from sprocket Replace belt
	Belt ran off rear sprocket	<ul style="list-style-type: none"> Your belt could be damaged. A new belt is recommended. Check to make sure sprockets are properly aligned Verify the correct amount of spacers have been used for the rear sprocket Realign drive system and tension belt
	Stripped Teeth, Root Cracking or Worn Belt	<ul style="list-style-type: none"> Replace belt
Noise: Clicking	Tolerance Issue with 3-Lobe Sprocket	<ul style="list-style-type: none"> Replace with SureFit sprocket
	Chainring bolts coming loose	<ul style="list-style-type: none"> Tighten chainring bolts
Tension Loss in Drive System	Change in distance between sprockets	<ul style="list-style-type: none"> Check to see if the rear wheel or dropout has moved Check to see if the tensioning device has been affected Reposition rear wheel in dropouts Re-tension the belt and measure using an approved tool
Tension Readings Excessive variation of tension readings in the belt after proper installation	Non-concentric assembly of sprocket/crank arm	<ul style="list-style-type: none"> Loosen chainring bolts and center sprocket on crank arm tabs Re-tighten chainring bolts
For additional technical support, see page 71.		

Axial Crank Run-Out

The amount of right to left crank arm tab movement relative to the centerline of the frame when rotating the cranks. Also referred to as wobble.

Belt Alignment

Refers to the parallel (side to side) and angular (toe in - toe out) alignment of the belt.

Belt Frequency

A term used in tensioning the belt. The natural frequency of a belt depends on the tension inside of the belt and distance between sprockets; the higher the tension the higher the frequency. Measurement of the belt frequency requires the Gates Carbon Drive Tensioning app or the Gates Sonic Tension Meter.

Belt Installation Distance

The minimum distance between center of the bottom bracket and rear axle needed to install the belt on the sprockets loosely. Initial installation of the belt loosely on the sprockets is required in order to avoid damaging the belt.

Belt Line

The distance from the center line on the belt in relation to the centerline of the frame. See Belt Line Specification pages.

Belt Pitch

The distance from the center of one tooth to the center of the next tooth. This measurement is different than a chain.

Belt Tension

The amount of tension experienced inside of a loaded belt. Belts require correct tensioning. Proper installation tension keeps the belt from jumping teeth and increases the life of the belt.

Center Distance

The distance from center of the bottom bracket to center of the rear axle.

Eco Tension Tester

A tool used to set proper belt tension.

Frame Break

A feature of the frame enabling a split or gap in the frame structure allowing belt installation into the rear triangle. Unlike a chain, a belt is continuous and cannot be broken and reconnected, therefore a separation in the frame is required for belt installation.

Frame Stiffness

Refers to a frame's resistance to flex for a given load applied. Stiffness plays a vital role in the operation of a belt drive. Too much flex can cause tooth jump, mis-alignment, noise, and wear.

Gear Inches

A system of measurement used to compare gear ratios based on the distance a bike travels with one pedal rotation.

Krikkit Gauge

A handheld tool used to set proper belt tension.

Profile

Refers to the shape of the belt tooth and sprocket groove.

Radial Crank Run-Out

The amount of "out-of-roundness" of crank arm tabs when rotating the cranks. Also referred to as Eccentricity. This type of run out is usually detected through tension variations in the belt leading to tight and loose spots in the belt.

Snubber

A device typically used on Rohloff drivetrains to increase belt wrap on the rear sprocket to help prevent the belt from skipping. A typical place for a snubber would be on the entry point of the belt into the rear sprocket (slack side).

Sonic tension meter

High precision electronic tool typically used by factories to set proper belt tension.

Sprocket

Using belt drive terminology, the term sprocket is used in place of rear cog and front chainring.

Sprocket Clearance

Distance from the closest edge of a front or rear sprocket to the frame. Belt drive sprockets are wider than chain rings, so clearance requirements must be considered.

Sprocket Wrench

A tool used to hold the rear sprocket in order to remove the rear cassette lockring. A sprocket wrench is the equivalent of a chain whip used for removing cogs on standard chain drive systems. Never use the Carbon Drive belt as a sprocket wrench.

Synchronous

Refers to drive systems using toothed belts in mesh with grooved sprockets.

Tensioned Center Distance

The distance between the center of the front sprocket and rear sprocket at proper belt tension for a given drive ratio.

Tooth Jump

Occurs when the belt tooth misses an engagement with a sprocket groove. This is typically due to incorrect belt tension.

Tooth Outer Diameter

The outer most diameter (OD) of the sprocket teeth.

WARRANTY

CARBON DRIVE™ SYSTEMS LIMITED PRODUCT WARRANTY

We make this quality commitment: at the time of sale to our customers, Gates Carbon Drive Systems Products (belts, sprockets, and accessories used in the bicycle market) will be free from defects in materials and workmanship. Further, the Products will meet our written specifications and standards. Products will be warranted only to the original retail purchaser for a period of two years from the original date of purchase. If we determine a product does not comply, we will, at our option, replace or repair the product. This is your exclusive remedy.

Damage to the product due to abuse, improper use, inadequate maintenance, or failure to follow Gates Carbon Drive Systems' published recommendations for installation, use and service will automatically void this warranty. Before using this product, please read the handling and installation instructions carefully (a copy of which is located at <http://www.GatesCarbonDrive.com/Tech/Overview>). For warranty service, please contact the retailer from whom the product was purchased.

THERE IS NO OTHER EXPRESS WARRANTY. FURTHER, WE DISCLAIM ALL IMPLIED WARRANTIES, INCLUDING THE WARRANTIES OF FITNESS FOR A PARTICULAR PURPOSE AND MERCHANTABILITY. LIABILITY FOR CONSEQUENTIAL, INCIDENTAL AND PUNITIVE DAMAGES UNDER ANY AND ALL LEGAL THEORIES IS EXCLUDED.

Some states do not allow the exclusion or limitation of damages, and some states do not allow limitations on how long a warranty lasts, so the above limitation and exclusion may not apply to you. This warranty gives you specific legal rights, and you may also have other rights which vary from state to state.

Return Policy: Gates Carbon Drive Systems Belts cannot be returned or exchanged.

For more information in Europe contact:

Gates Carbon Drive – Germany Bicycle Lab
Mühlhausen, Germany
+49 (0) 3601 888 6484
info@carbondrive.net

www.GatesCarbonDrive.com

For more information in North and South America contact:

Gates Carbon Drive
Denver, Colorado
303-744-4593

CarbonDrive@Gates.com

CONTACTS



AMERICAS

303-744-4593
CarbonDrive@Gates.com

EUROPE

+49 (0) 3601 888 6484
info@CarbonDrive.net

ASIA

04-2301-6876 (from Taiwan)
+886-4-2301-6876
(from any Int'l location)
CarbonDrive.tw@gates.com

FOR OTHER LOCAL CONTACTS, VISIT WWW.GATESCARBONDRIVE.COM/OEM-FACTORY

Shimano, Alfine, Nexus are trademarks of Shimano Inc.
enviolo is a trademark of Fallbrook Technologies Inc.
Rohloff is a trademark of Rohloff AG.
Pinion is a trademark of Pinion GmbH
Effigear is a trademark of Ingeartec.
Bosch is a trademark of Robert Bosch GmbH.
BionX is a trademark of BionX International Corporation.
Yamaha is a trademark of Yamaha Motor Co., Ltd.
Panasonic is a trademark of Panasonic Corporation.
MPF is a trademark of MPF Drive.

Höganäs is a trademark of Höganäs AB.
SRAM, E-matic, i-Motion and AUTOMATIX are trademarks of SRAM LLC.
GoSwiss is a trademark of GO SwissDrive.
TranzX is a trademark of JD Europe Components GmbH.
iPhone is a trademark of Apple Inc.
Android is a trademark of Google Inc.
CDX, CDC, CDN, CDX:EXP, CDX:SL, CenterTrack, Carbon Drive, MudPort, SureFit, and the color Carbon Blue are trademarks of Gates Corporation.
Sturmey-Archer is a trademark of Sun Race Sturmey-Archer Inc.

